



Technical Bulletin

Driver Instruction Kit TP-9579

Index

- | | |
|--------------------|---|
| TP-9646 | Driver Controlled Main Differential Lock (DCDL)
All Meritor single rear drive axles with DCDL option |
| TP-9647 | Inter-Axle Differential (IAD)
All Meritor tandem drive axles |
| TP-9648 | Inter-Axle Differential (IAD) and Driver Controlled Main Differential (DCDL)
All Meritor tandem drive axles equipped with both IAD and DCDL |
| TP-9579A | Axle Preparation Instructions for Vehicle Towing or New Vehicle Drive-Away (Piggybacking)
Single axle without DCDL
Tandem axle without DCDL, with IAD |
| TP-9579B | Axle Preparation Instructions for Vehicle Towing or New Vehicle Drive-Away (Piggybacking)
Single axle with DCDL (threaded shift assembly)
Tandem axle with DCDL (threaded shift assembly) with IAD |
| TP-9579C | Axle Preparation Instructions for Vehicle Towing or New Vehicle Drive-Away (Piggybacking)
Single axle with DCDL (bolt-on shift assembly)
Tandem axle with DCDL (bolt-on shift assembly) with IAD |
| TP-9579ALBL | DCDL Label |
| TP-9781 | Installing the Meritor Driver Controlled Main Differential Lock (DCDL)
All single and tandem drive axles |



Technical Bulletin

Driver Controlled Main Differential Lock (DCDL) All Meritor Single Rear Drive Axles with DCDL Option

Introduction

The Meritor Driver Controlled Main Differential Lock (DCDL) is an air-actuated traction device that can be operated from the vehicle cab. By actuating an air plunger or electric switch, usually mounted on the instrument panel, the driver can lock or unlock main differential action. When the DCDL is actuated, an indicator light on the instrument panel will be on. When the DCDL is not actuated, the indicator light will be off. Additional devices may also be used to indicate the lock or unlock conditions, such as an audible signal. Refer to the vehicle owner's manual for DCDL operating instructions.

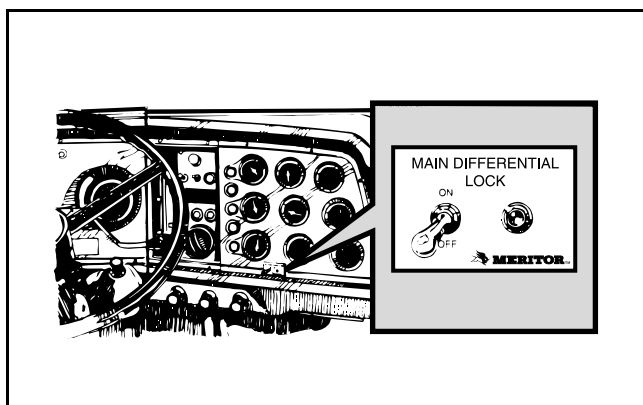

The purpose of the DCDL in a Meritor axle is to provide maximum vehicle traction and control on unfavorable road or highway surfaces. When the DCDL is actuated, a clutch collar completely locks the differential case, gearing, and axle shafts together. This feature maximizes traction to both wheels. The lock position will also protect against spinout damage to the differential. The DCDL should not be actuated when favorable road conditions exist.

Operation Tips

1. The DCDL can be locked or unlocked if the vehicle is standing still or moving at a constant low speed when the wheels are not spinning, slipping, or losing traction. If a high torque or spinning condition exists, relieve the condition by letting up on the accelerator prior to engaging the DCDL switch.
2. When the DCDL is locked, operate the vehicle at low speeds, under 25 mph.
3. When the DCDL is locked, the vehicle's turning radius will increase. This condition is called "understeer." The driver must use caution, good judgment and drive at low speeds when operating the vehicle with the DCDL locked.
4. Always unlock the DCDL as soon as the need for maximum traction has passed and the vehicle is traveling on a good road or highway.
5. Do not lock the DCDL when the wheels are slipping or losing traction, or damage to the axle can result.
6. Do not lock the DCDL when the vehicle is traveling down steep grades, or potential loss of vehicle stability could result in a jackknife of tractor and trailer.

Driver Instructions

Locking the DCDL

When encountering poor road or highway conditions where maximum traction is needed, follow the recommended procedures:

1. Without the wheels spinning, slipping or losing traction, flip the DCDL control switch to the "LOCK" position while maintaining a constant vehicle speed under 25 mph.

NOTE: The DCDL system of some vehicles is connected through the low speed range of the transmission. If this type of differential lock system is used, the transmission **MUST** be operating in the low speed range to allow the differential to lock.

2. Let up momentarily on the accelerator to relieve torque on the gearing, allowing the DCDL to lock.
3. When the DCDL is activated, the indicator light will be on and there may also be an audible signal.
4. When the DCDL is fully locked, the vehicle will have an "understeer" condition when making turns. Proceed cautiously over poor road or highway conditions, **NEVER** exceed 25 mph, and use good driving judgment.

Unlocking the DCDL

When the vehicle can safely operate at speeds above 25 mph and driving conditions have improved, disengage the DCDL following the recommended procedures:

1. Flip the control switch to the "UNLOCK" position, when the vehicle is stopped or when traveling below 25 mph while the wheels are not spinning, slipping or losing traction.
2. Let up momentarily on the accelerator to relieve torque on the gearing, allowing the DCDL to unlock. It may take up to 1/2 mile of driving before the differential unlocks.

NOTE: If the DCDL system is connected through the low speed range of the transmission, shifting out of low speed range will also unlock the differential.

NOTE: Be aware that it is possible for the assembly to become torque bound if the condition requiring differentiation is not relieved prior to moving the switch to the OFF position. In a torque-bound condition, the light will continue to illuminate, indicating the lock is still engaged. Typically, it will disengage during normal maneuvering. Under some conditions, however, stopping and shifting to Neutral will relieve the torque-bound condition and allow disengagement.

3. When the DCDL is deactivated, the indicator light will be off or the audible signal will stop.
4. Resume driving at normal speed using good driving judgment.





Technical Bulletin

Inter-Axle Differential (IAD) All Meritor Tandem Drive Axles

Introduction

The Meritor Inter-Axle Differential (IAD) is a driver-controlled, air-actuated traction device that allows for speed differences between the forward and rear tandem axles while providing equal pulling power from each axle of the tandem. By activating the IAD switch located in the vehicle dash, improved traction is provided for each axle.

The Inter-Axle Differential (IAD) is also known as a "Power Divider" or "Third" differential.

Operation Tips

1. The IAD is driver controlled.
2. The IAD switch should be in the "UNLOCK" position for normal operating conditions where there is good traction.
3. Lock the IAD when approaching or anticipating icy or poor driving conditions to provide improved traction. Relieve torque prior to engaging the switch by letting up on the accelerator pedal.
4. Always unlock the IAD when the need for improved traction has passed or when the vehicle is on a good road or highway.
5. After locking or unlocking the IAD, let up on the accelerator to provide an interruption in torque to the drivetrain. Activating the IAD lock is similar to shifting a manual transmission with a clutch.
6. Do not actuate the IAD switch while one or more wheels are actually slipping, spinning or losing traction, or damage to the axle can result.
7. Do not spin the wheels with the IAD unlocked, or damage to the axle could result.

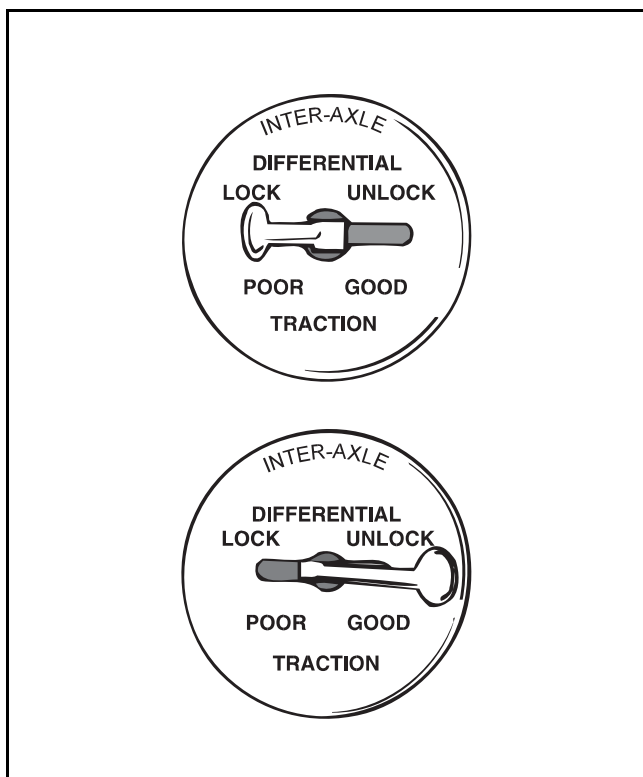

Driver Instructions

Locking the IAD

When encountering poor road or highway conditions where a decrease in traction is anticipated, follow the recommended procedures:

1. Let up momentarily on the accelerator to relieve torque on the gearing and any spinning conditions.
2. Flip the IAD switch to the "LOCK" position. The differential lock will engage.
3. Proceed to drive cautiously.

Unlocking the IAD

When poor road or highway conditions have passed, follow these steps to UNLOCK the IAD:

1. Flip the switch to the "UNLOCK" position while maintaining vehicle speed.
2. Let up momentarily on the accelerator. The differential lock will promptly disengage.
3. Resume a safe vehicle speed.





Technical Bulletin

Inter-Axle Differential (IAD), and Driver Controlled Main Differential Lock (DCDL)

All Meritor Tandem Drive Axles
Equipped with Both the
Inter-Axle Differential (IAD), and
Driver Controlled Differential Lock (DCDL)

Introduction

All Meritor tandem axles are equipped with Inter-Axle Differential or IAD. Drivers may lock the IAD to improve traction when encountering adverse winter road conditions. The IAD lock may be used at all speeds and for long time periods depending on bad weather conditions such as rain or snow.

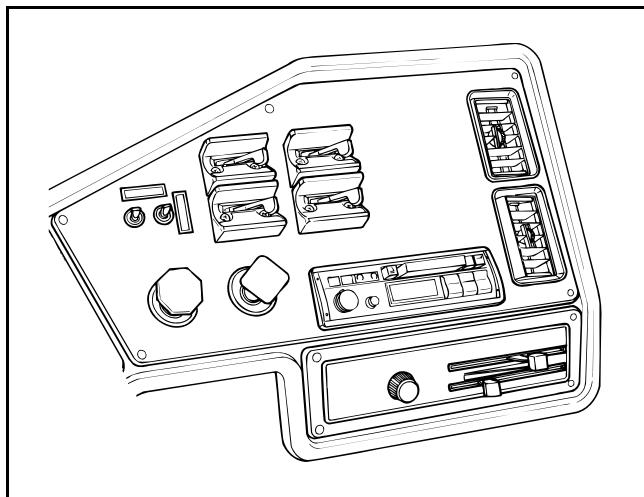

Optional DCDL is available in either the forward axle only, the rear axle only or in both axles of the tandem. This option is available on most models of Meritor tandem axles. The DCDL is used during on- and off-highway operations that encounter slippery road conditions and/or uneven terrain. It is used only at low speeds while traveling through an area with poor traction conditions and is deactivated as soon as the vehicle is through the area.

Drivers may lock BOTH the IAD and the DCDL for maximum traction under icy, snowy or poor road conditions. However, when using both of these traction-enhancement devices or the DCDL alone, vehicle speed must remain at 25 mph or less.

Recommended Procedures for using Both the IAD Lock and DCDL Lock

When encountering poor road or highway conditions where maximum traction is required, perform the following:

1. When approaching poor traction conditions, first engage the IAD switch. As conditions worsen and when vehicle travel speed is 25 mph or less, the DCDL lock can then be engaged.
2. When the DCDL is locked, the vehicle's turning radius will increase. This condition is called "understeer." The driver must use caution, good judgment and drive at low speeds when operating the vehicle with the DCDL locked.
3. There are no speed or handling restrictions for vehicle operation with the IAD lock engaged. But for best axle performance and minimum tire wear, ALWAYS unlock the IAD lock when favorable road conditions return.
4. When the DCDL is locked, the vehicle must be operated at 25 mph or less. Lock the DCDL only when maximum traction is needed.
5. Do not lock the DCDL when the vehicle is traveling down steep grades, or potential loss of vehicle stability could result in a jackknife of tractor and trailer.

6. Use these traction devices accordingly:

IAD Lock — First	DCDL Lock — Second
Provides improved traction to both the forward and rear drive axles of a tandem.	Provides maximum traction potential to each wheel end of an axle.
May be applied at any speed (assuming both axles are rolling and that spinout has not started to occur) and/or remain engaged for long periods of time depending on weather conditions such as snow, sleet, or rain.	To be applied for very short periods of time and at very low speeds (25 mph or less) due to the possible effects on handling characteristics of the vehicle with the lock engaged.
Manually turned on and off by a switch in the cab.	Manually turned on and off by a switch, but also set up to automatically shut off, in most instances, when a predetermined vehicle speed is obtained.

Drivers Instructions

Locking the IAD

When encountering poor road or highway conditions where a decrease in traction is anticipated, follow the recommended procedures:

1. Let up momentarily on the accelerator to relieve torque on the gearing and any spinning conditions.
2. Flip the IAD switch to the "LOCK" position. The differential lock will engage.
3. Proceed to drive cautiously.

Locking the DCDL

When encountering poor road or highway conditions where vehicle speed is 25 mph or less and maximum traction is needed, follow the recommended procedures:

1. Without the wheels spinning, slipping or losing traction, flip the control switch to the "LOCK" position while maintaining a constant vehicle speed under 25 mph.

NOTE: The differential lock system of some vehicles is connected through the low speed range of the transmission. If this type of differential lock system is used, the transmission **MUST** be operating in the low speed range to allow the differential to lock.

2. Let up momentarily on the accelerator to relieve torque on the gearing, allowing the differential to lock.
3. When the differential lock is activated, the indicator light will be on and there may also be an audible signal.
4. When the DCDL is fully locked, the vehicle will have an "understeer" condition when making turns. Proceed cautiously over poor road or highway conditions at 25 mph or less using good driving judgment.

Unlocking the DCDL

When the vehicle can safely operate at speeds above 25 mph and driving conditions have improved, disengage the DCDL following the recommended procedures:

1. Flip the control switch to the "UNLOCK" position.
2. Let up momentarily on the accelerator to relieve torque on the gearing, allowing the DCDL to unlock. It may take up to 1/2 mile of driving before the differential unlocks.

NOTE: If the DCDL is connected through the low speed range of the transmission, shifting out of low speed range will also unlock the differential.

NOTE: Be aware that it is possible for the assembly to become torque bound if the condition requiring differentiation is not relieved prior to moving the switch to the OFF position. In a torque-bound condition, the light will continue to illuminate, indicating the lock is still engaged. Typically, it will disengage during normal maneuvering. Under some conditions, however, stopping and shifting to Neutral will relieve the torque-bound condition and allow disengagement.

3. When the differential lock is deactivated, the indicator light will be off or the audible signal will stop.
4. Resume driving at normal speed using good driving judgment.

Unlocking the IAD

When poor road or highway conditions have passed, follow these steps to unlock the IAD:

1. Flip the switch to the "UNLOCK" position while maintaining vehicle speed.
2. Let up momentarily on the accelerator. The differential lock will promptly disengage.
3. Resume a safe vehicle speed.

Locking Both the IAD and the DCDL

1. When electing to use both the IAD lock and the DCDL, first engage the IAD lock, and when the vehicle speed falls to 25 mph or below, engage the DCDL.
2. Engage the IAD lock at any speed except when a wheel is slipping, spinning or losing traction.
3. Engage the DCDL only when the vehicle is traveling at 25 mph or less and when the wheels are not slipping, spinning or losing traction.

Unlocking Both the DCDL and the IAD

1. When traction conditions improve, disengage the DCDL before vehicle speed exceeds 25 mph.
2. Never disengage the DCDL (or the IAD) lock if the vehicle wheels are slipping, spinning or losing traction.
3. Disengage the DCDL when the vehicle is capable of achieving a travel speed above 25 mph.
4. Disengage the IAD lock when road conditions return to normal and further adverse road conditions are not anticipated.



Meritor Heavy Vehicle Systems, LLC
2135 West Maple Road
Troy, MI 48084 U.S.A.
866-OnTrac1 (668-7221)
meritor.com

Information contained in this publication was in effect at the time the publication was approved for printing and is subject to change without notice or liability. Meritor Heavy Vehicle Systems, LLC, reserves the right to revise the information presented or to discontinue the production of parts described at any time.

© Copyright 2018
Meritor, Inc.
All Rights Reserved

Printed in the USA

TP-9648
Revised 11-18
(16579)



Axle Preparation Instructions for Vehicle Towing or New Vehicle Drive-Away (Piggybacking)

TYPE OF AXLE:

SINGLE AXLE, without Driver Controlled Main Differential Lock (DCDL)

TANDEM AXLE, without Driver Controlled Main Differential Lock (DCDL), with Inter-Axle Differential (IAD)

ADDITIONAL AXLE PREPARATION INSTRUCTIONS:

Single and Tandem Axles with DCDL, Threaded Shift Assembly — Refer to Technical Bulletin, TP-9579B

Single and Tandem Axles with DCDL, Bolted On Shift Assembly — Refer to Technical Bulletin, TP-9579C

These instructions are for vehicles equipped with Meritor single or tandem rear drive axles.

The instructions supersede all other instructions for the purpose of transporting vehicles for service or new vehicle drive-away dated before April 1995, including those contained in Meritor maintenance manuals.

When transporting a vehicle with the wheels of one or both drive axles on the road, it is possible to damage the axles if the wrong procedure is used before transporting begins. Meritor recommends that you use the following procedure.

Before Towing or Drive-Away (Piggybacking)

WARNING

To prevent serious eye injury, always wear safe eye protection when you perform vehicle maintenance or service.

WARNING

Engage the parking brake to prevent the vehicle from moving before you begin maintenance or service procedures that require you to be under the vehicle. Serious personal injury can result.

1. Apply the vehicle parking brakes using the switch inside the cab of the vehicle.
2. Shift the transmission into neutral and start the vehicle's engine.
3. Shift the IAD to the locked (engaged) position using the switch inside the cab of the vehicle. The IAD indicator light in the cab will go on.
4. Stop the engine.

NOTE: Remove both axle shafts from the axle(s) that will remain on the road when the vehicle is transported. Continue with Step 5 for **BOTH** axle shafts.

5. Remove the stud nuts or capscrews and the washers from the flange of the axle shaft. **Figure 1.**
6. Loosen the tapered dowels, if used, in the flange of the axle shaft using one of the two following methods. **Figure 1.**

CAUTION

Do not use a chisel or wedge to loosen the axle shaft and dowels. The chisel or wedge can damage the hub, axle shaft and gasket, if used.

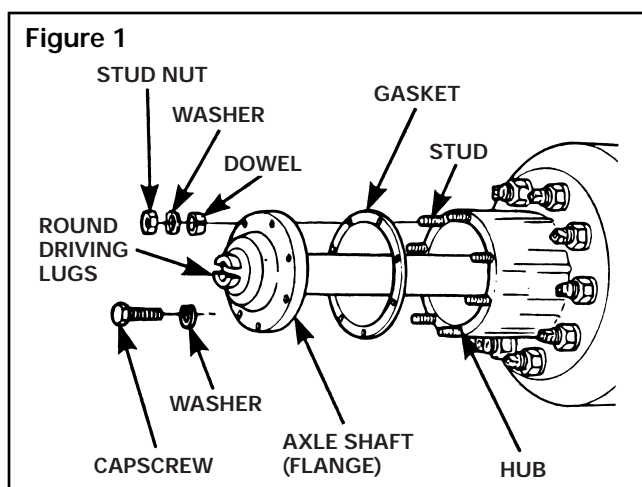

Brass Drift Method:

WARNINGS

To prevent serious eye injury, always wear safe eye protection when you perform vehicle maintenance or service.

WARNING

Do not strike the round driving lugs on the flange of an axle shaft. Pieces can break off and cause serious personal injury.

NOTE: A 1.5-inch (38.1 mm) diameter brass hammer can be used as a drift.

- a. Hold a 1.5-inch (38.1 mm) diameter brass drift against the center of the axle shaft flange, **INSIDE THE ROUND DRIVING LUGS**. **Figure 2.**

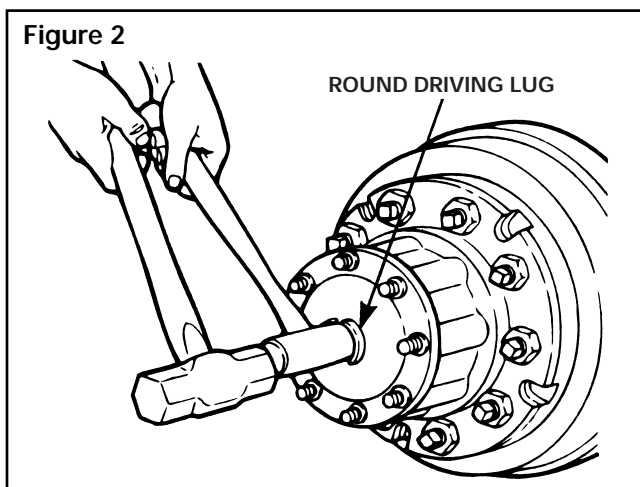

- b. Hit the end of the drift with a large hammer (5 to 6 pounds, 2.3 to 2.7 kg) to loosen the axle shaft and tapered dowels from the hub. **Figure 2.**

Air Hammer Method:

WARNINGS

To prevent serious eye injury, always wear safe eye protection when you perform vehicle maintenance or service.

- a. Use an air hammer, such as Chicago Pneumatic CP-4181-PULER, or equivalent, with a round hammer bit to loosen the axle shaft and dowels.
- b. Put the round hammer bit against the axle shaft flange between the studs, at different points around the flange. Operate the air hammer at each location and loosen the axle shaft and tapered dowels from the hub. **Figure 3.**

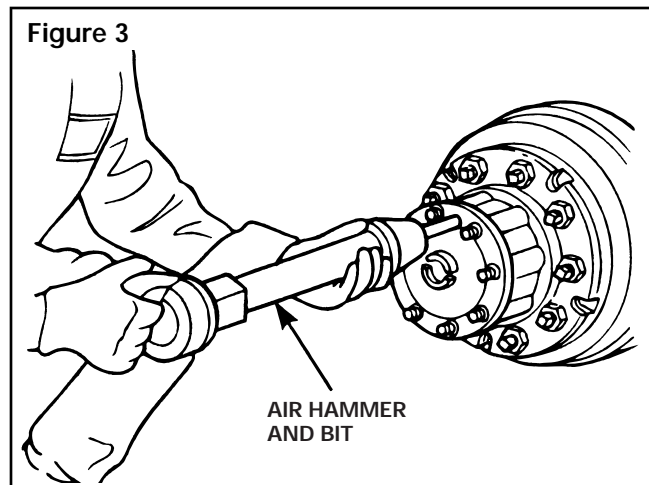

7. Identify each axle shaft that is removed from the axle assembly so they can be installed in the same location after transporting or repair is completed. (Example: Match mark a mating axle shaft and hub.)
 8. Remove the tapered dowels, gasket (if used) and the axle shaft from the axle assembly. **Figure 1.**
 9. Install a cover over the open end of each hub where an axle shaft was removed. This will prevent dirt from entering the bearing cavity and loss of lubricant.
- NOTE:** If an air supply will be used for the brake system of the transported vehicle, continue with Steps 10 and 11, otherwise continue with Step 12.
10. Connect an auxiliary air supply to the brake system of the vehicle that is being transported. Before moving the vehicle, charge the brake system with the correct amount of air pressure to operate the brakes. Refer to the instructions supplied by the manufacturer of the vehicle for procedures and specifications. If an auxiliary air supply is not used, continue with Step 12.
 11. When the correct amount of air pressure is in the brake system, release the parking brakes of the vehicle that is being transported. Step 12 is not required.

WARNING

When you work on a spring chamber, carefully follow the service instructions of the chamber manufacturer. Sudden release of a compressed spring can cause serious personal injury.

12. If there are spring (parking) brakes on the axle(s) that will remain on the road when the vehicle is transported, and they cannot be released by air pressure, manually compress and lock each spring so that the brakes are released. Refer to the manufacturer's instructions.

After Towing or Drive-Away (Piggybacking)



WARNING

To prevent serious eye injury, always wear safe eye protection when you perform vehicle maintenance or service.



WARNING

Engage the parking brake to prevent the vehicle from moving before you begin maintenance or service procedures that require you to be under the vehicle. Serious personal injury can result.

1. If an auxiliary air supply was used, apply the vehicle parking brakes using the switch inside the cab of the vehicle. If an auxiliary air supply was not used, begin with Step 2.



WARNING

When you work on a spring chamber, carefully follow the service instructions of the chamber manufacturer. Sudden release of a compressed spring can cause serious personal injury.

2. Apply the vehicle spring (parking) brakes by manually releasing each spring that was compressed before transporting started. Refer to manufacturer's instructions.
3. Disconnect the auxiliary air supply, if used, from the brake system of the vehicle that was transported. Connect the vehicle's air supply to the brake system.
4. Remove the covers from the hubs.

NOTE: Continue with Steps 5-7 to install all axle shafts.

5. Install the gasket, if used, and axle shaft into the axle housing and carrier in the same location it was removed from. The gasket and flange of the axle shaft must be flat against the hub. Rotate the axle shaft and/or the driveline as necessary to align the splines and the holes in the flange with the studs in the hub.

Figure 1.

6. Install the dowels, if used, over each stud and into the tapered holes of the flange.
7. Install the washers and capscrews or stud nuts. Determine the size of the fasteners and tighten the capscrews or nuts to the corresponding torque value shown in the table to the right.

	Thread Size	Torque Value lb-ft (N•m) 
Capscrews:	0.31" - 24	18 - 24 (24 - 33)
	0.50" - 13	85 - 115 (115 - 156)
Stud Nuts: (plain nuts)	0.44" - 20	50 - 75 (68 - 102)
	0.50" - 20	75 - 115 (102 - 156)
	0.56" - 18	110 - 165 (149 - 224)
	0.62" - 18	150 - 230 (203 - 312)
	0.75" - 16	310 - 400 (420 - 542)
(locknut)	0.44" - 20	40 - 65 (54 - 88)
	0.50" - 20	65 - 100 (88 - 136)
	0.56" - 18	100 - 145 (136 - 197)
	0.62" - 18	130 - 190 (176 - 258)
	0.75" - 16	270 - 350 (366 - 475)

8. Check the lubricant level in the axles and hubs where the axle shafts were removed. Add the correct type and amount of lubricant if necessary. For information about lubrication, refer to the Meritor Maintenance Manual, MM No. 1, *Lubrication*, or refer to the lubrication section of the Meritor maintenance manual for the axle model you are working with.



Meritor Heavy Vehicle Systems, LLC
2135 West Maple Road
Troy, MI 48084 U.S.A.
800-535-5560
www.meritorauto.com

Information contained in this publication was in effect at the time the publication was approved for printing and is subject to change without notice or liability. Meritor Heavy Vehicle Systems, LLC, reserves the right to revise the information presented or discontinue the production of parts described at any time.

© Copyright 1995
Meritor Automotive, Inc.
All Rights Reserved

Printed in the USA
Please Recycle

TP-9579A
Issued 7-95
16579/22882



Axle Preparation Instructions for Vehicle Towing or New Vehicle Drive-Away (Piggybacking)

TYPE OF AXLE:

SINGLE AXLE, with Driver Controlled Main Differential Lock (DCDL — threaded shift assembly)

TANDEM AXLE, with Driver Controlled Main Differential Lock (DCDL — threaded shift assembly), with Inter-Axle Differential (IAD)

ADDITIONAL AXLE PREPARATION INSTRUCTIONS:

Single and Tandem Axles without DCDL, and Tandem with IAD — Refer to Technical Bulletin, TP-9579A

Single and Tandem Axles with DCDL, Bolted On Shift Assembly — Refer to Technical Bulletin, TP-9579C

These instructions are for vehicles equipped with Meritor single or tandem rear drive axles.

The instructions supersede all other instructions for the purpose of transporting vehicles for service or new vehicle drive-away dated before April 1995, including those contained in Meritor maintenance manuals.

When transporting a vehicle with the wheels of one or both drive axles on the road, it is possible to damage the axles if the wrong procedure is used before transporting begins. Meritor recommends that you use the following procedure.

Before Towing or Drive-Away (Piggybacking)



WARNING

To prevent serious eye injury, always wear safe eye protection when you perform vehicle maintenance or service.



WARNING

Engage the parking brake to prevent the vehicle from moving before you begin maintenance or service procedures that require you to be under the vehicle. Serious personal injury can result.

1. Apply the vehicle parking brakes using the switch inside the cab of the vehicle.
2. Shift the transmission into neutral and start the vehicle's engine.
3. Shift the DCDL to the unlocked (disengaged) position using the switch inside the cab of the vehicle. The DCDL indicator light in the cab will go off. Shift the IAD to the unlocked (disengaged) position using the switch inside the cab of the vehicle. The IAD indicator light in the cab will go off (if equipped).
4. Stop the engine.
5. Refer to Table A and identify which axle shafts must be removed based on how the vehicle will be towed.

Table A

Single Axles
Remove both axle shafts.
Tandem Axles
Forward Axle (Towing from Front): No need to remove axle shafts.
Forward Axle (Towing from Rear): Remove both axle shafts.
Rear Axle (Towing from Front): Remove both axle shafts.
Rear Axle (Towing from Rear): No need to remove axle shafts.

6. On axles equipped with a DCDL, the shift collar splines must be engaged with the differential case splines before removing the axle shaft. Engage the DCDL shift collar using the Manual Engaging Method as follows.

CAUTION

On single and tandem rear axles equipped with a DCDL, when removing the curb-side (right) axle shaft, the DCDL shift collar splines must be engaged with the differential case splines. The collar splines must be completely engaged with the differential case splines. This must be done to prevent the shift collar from dropping out of position when removing the axle shaft. Cage (engage) the shift collar with the differential case before removing the axle shaft or damage to components can result.

- a. Disconnect the air hose from the shift cylinder. **Figure 1.**

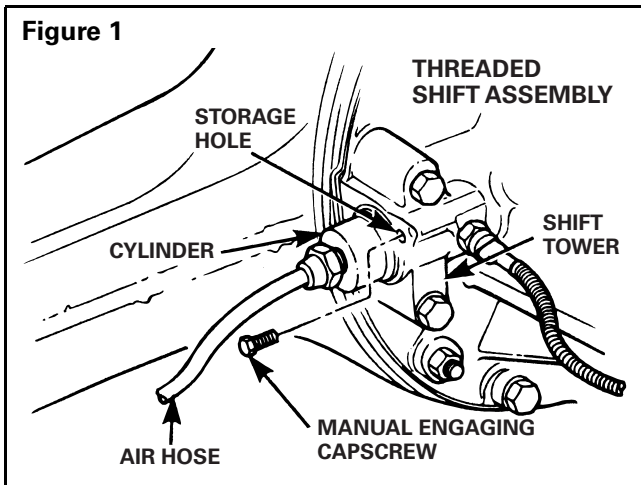

- b. Remove the manual engaging cap screw from the storage hole. The storage hole of threaded shift assemblies is located in the shift tower of the carrier, next to the cylinder. **Figure 1.**
- c. Install the manual engaging cap screw into the threaded hole in the center of the cylinder. **Figure 2.**

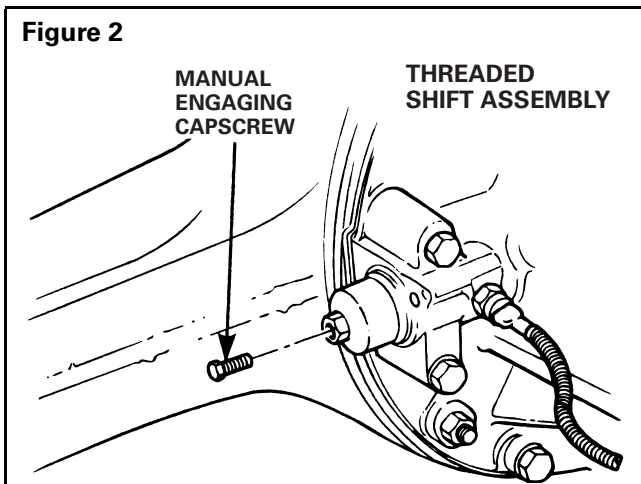

CAUTION

When you turn the cap screw in Step d and you feel a high resistance, STOP TURNING THE CAPSCREW. A high resistance against the cap screw indicates that the splines of the shift collar and differential case are not aligned. Damage to the threads of the cylinder and cap screw will result. To align the splines, continue with Steps e and f.

- d. Turn the cap screw to the right until the head is approximately 0.25 to 0.50-inch (6.4 to 12.7 mm) from the cylinder. The cap screw is now in the service position and the DCDL shift collar is locked (engaged). **Figure 3.** When turning the cap screw you will feel a small amount of resistance. This is normal. If you feel a high resistance before achieving the 0.25- to 0.50-inch distance between the cap screw head and cylinder, **STOP TURNING THE CAPSCREW** and continue with Steps e and f.

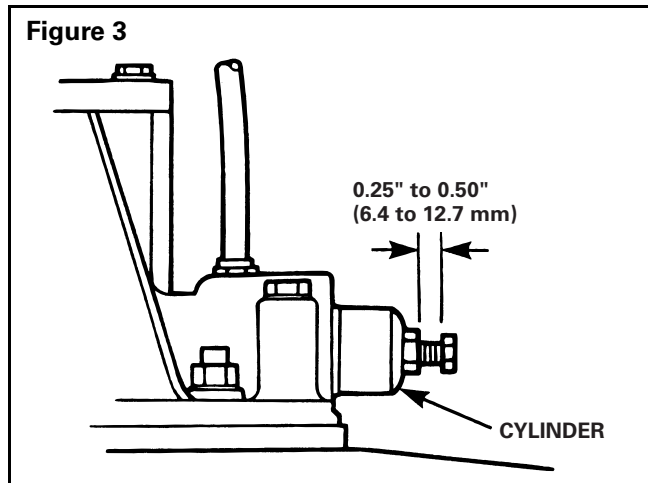

- e. Raise the tire and wheel (DCDL axle side) off of the floor (leave the opposite tire and wheel on the floor) and support the axle with jack stands. Slowly rotate the wheel of the DCDL axle shaft that is to be removed by hand.
- f. Verify that the clutch collar is engaged by attempting to rotate the elevated wheel. If it does not rotate, the collar is successfully caged. The axle shaft can now be removed.
 - **If you still feel a high resistance:** Stop turning the cap screw, disassemble and inspect components for damage and wear. Replace as necessary.

7. Identify each axle shaft so they can be installed in the same location after transporting or repair is completed. (Example: Match mark a mating axle shaft and hub.)
8. Remove the stud nuts or capscrews and the washers from the flange of the axle shaft. **Figure 4.**
9. Loosen the tapered dowels, if used, in the flange of the axle shaft using one of the two following methods. **Figure 4.**

CAUTION

Do not use a chisel or wedge to loosen the axle shaft and dowels. The chisel or wedge can damage the hub, axle shaft and gasket, if used.

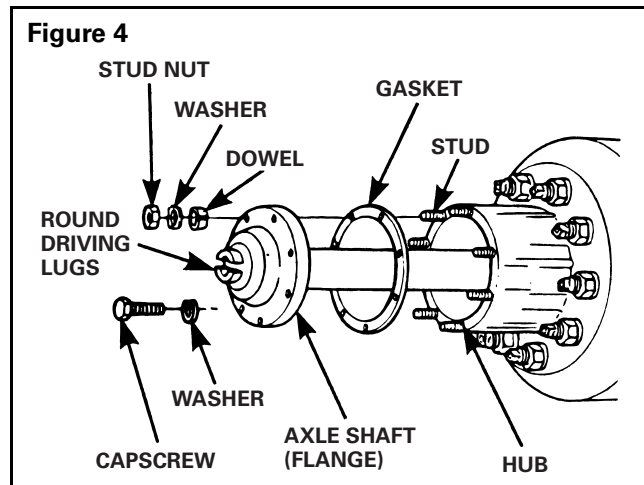

Brass Drift Method:

WARNING

Do not strike the round driving lugs on the flange of an axle shaft. Pieces can break off and cause serious personal injury.

NOTE: A 1.5-inch (38.1 mm) diameter brass hammer can be used as a drift.

- a. Hold a 1.5-inch (38.1 mm) diameter brass drift against the center of the axle shaft flange, **INSIDE THE ROUND DRIVING LUGS**. **Figure 5.**

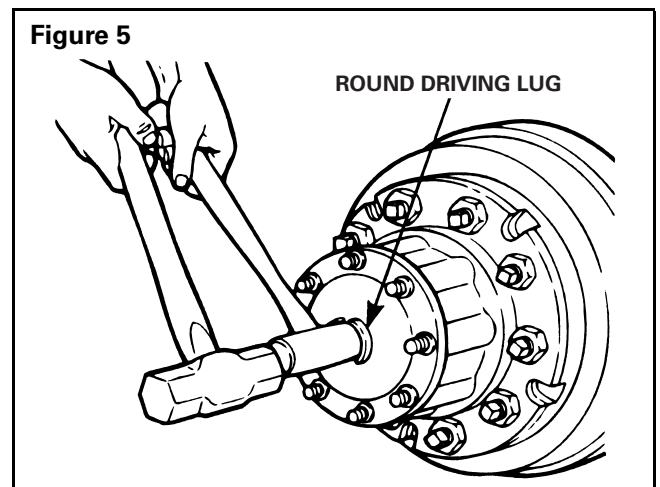

- b. Hit the end of the drift with a large hammer (5 to 6 pounds, 2.3 to 2.7 kg) to loosen the axle shaft and tapered dowels from the hub. **Figure 5.**

Air Hammer Method:

WARNING

To prevent serious eye injury, always wear safe eye protection when you perform vehicle maintenance or service.

- a. Use an air hammer, such as Chicago Pneumatic CP-4181-PULER, or equivalent, with a round hammer bit to loosen the axle shaft and dowels.
- b. Put the round hammer bit against the axle shaft flange between the studs, at different points around the flange. Operate the air hammer at each location and loosen the axle shaft and tapered dowels from the hub. **Figure 6.**

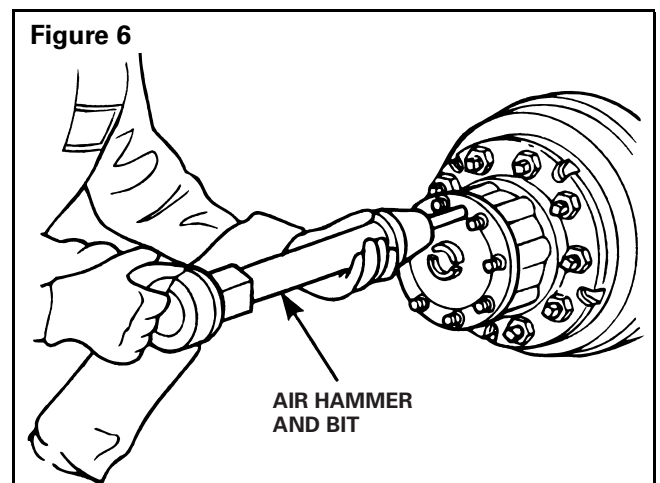

10. Remove the tapered dowels, the axle shafts and gaskets (if used). **Figure 4.**
11. Remove the remaining axle shaft(s) as necessary from the axle(s) that will remain on the road when the vehicle is transported according to Table A.
12. Install a cover over the open end of each hub where an axle shaft was removed. This will prevent dirt from entering the bearing cavity and minimize loss of lubricant.

NOTE: If an air supply will be used for the brake system of the transported vehicle, continue with Steps 13 and 14, otherwise continue with Step 15.

13. Connect an auxiliary air supply to the brake system of the vehicle that is being transported. Before moving the vehicle, charge the brake system with the correct amount of air pressure to operate the brakes. Refer to the instructions supplied by the manufacturer of the vehicle for procedures and specifications. If an auxiliary air supply is not used, continue with Step 15.
14. When the correct amount of air pressure is in the brake system, release the parking brakes of the vehicle that is being transported. Step 15 is not required.



WARNING

When you work on a spring chamber, carefully follow the service instructions of the chamber manufacturer. Sudden release of a compressed spring can cause serious personal injury.

15. If there are spring (parking) brakes on the axle(s) that will remain on the road when the vehicle is transported, and they cannot be released by air pressure, manually compress and lock each spring so that the brakes are released. Refer to the manufacturer's instructions.

After Towing or Drive-Away (Piggybacking)



WARNING

To prevent serious eye injury, always wear safe eye protection when you perform vehicle maintenance or service.



WARNING

Engage the parking brake to prevent the vehicle from moving before you begin maintenance or service procedures that require you to be under the vehicle. Serious personal injury can result.

1. If an auxiliary air supply was used, apply the vehicle parking brakes using the switch inside the cab of the vehicle. If an auxiliary air supply was not used, begin with Step 2.



WARNING

When you work on a spring chamber, carefully follow the service instructions of the chamber manufacturer. Sudden release of a compressed spring can cause serious personal injury.

2. Apply the vehicle spring (parking) brakes by manually releasing each spring that was compressed before transporting started. Refer to manufacturer's instructions.
3. Disconnect the auxiliary air supply, if used, from the brake system of the vehicle that was transported. Connect the vehicle's air supply to the brake system.
4. Remove the covers from the hubs.

NOTE: Install the axle shafts indicated in **Table B**. Axle shafts with a DCDL have a double row of splines that engage with splines of the side gear and of the shift collar in the differential case. **Figure 7.** Continue with Step 5.

Table B

Single Axles
Remove both axle shafts.
Tandem Axles
Forward Axle (Towing from Front): No need to remove axle shafts.
Forward Axle (Towing from Rear): Remove both axle shafts.
Rear Axle (Towing from Front): Remove both axle shafts.
Rear Axle (Towing from Rear): No need to remove axle shafts.

NOTE: Make sure to engage the axle shaft splines for the differential side gear and the shift collar. They must be fully engaged.

5. Install the gasket, if used, and axle shaft into the axle housing and carrier in the same location it was removed from. The gasket and flange of the axle shaft must be flat against the hub. Rotate the axle shaft and/or the driveline as necessary to align the splines and the holes in the flange with the studs in the hub. **Figure 4.**
6. Install the dowels, if used, over each stud and into the tapered holes of the flange.

Figure 7

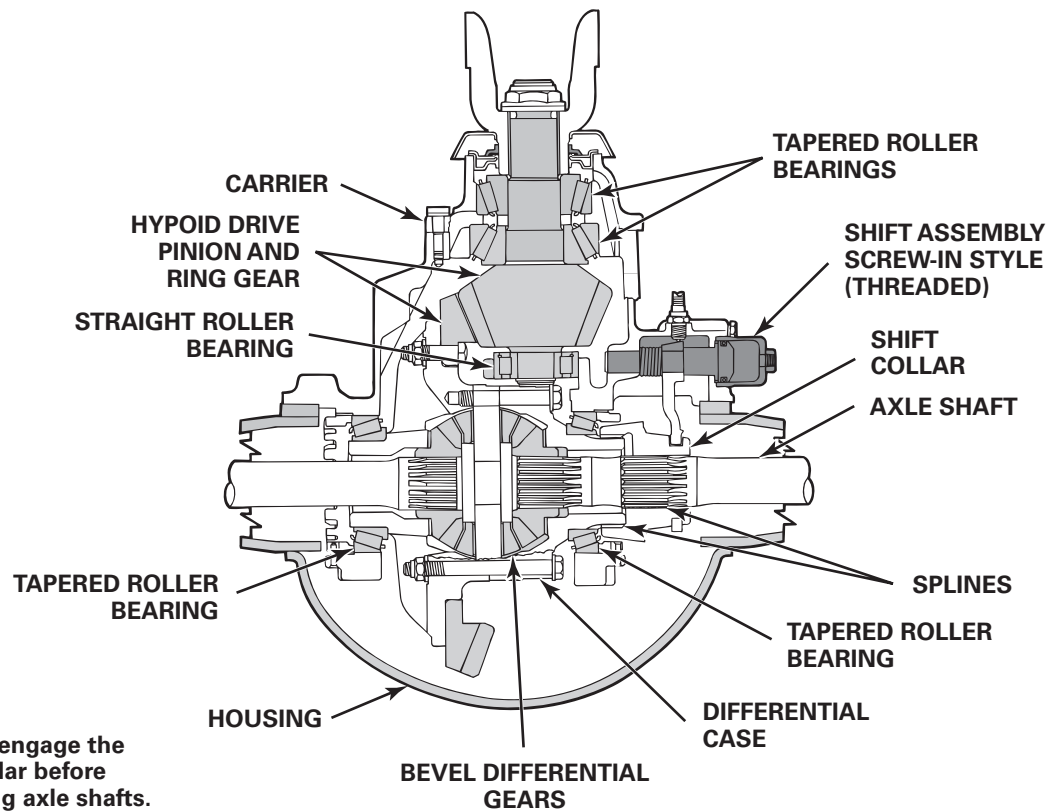

STANDARD CARRIER WITH DIFFERENTIAL LOCK (DCDL)



7. Install the washers and capscrews or stud nuts. Determine the size of the fasteners and tighten the capscrews or nuts to the corresponding torque value shown in **Table C**.

Table C

	Thread Size	Torque Value lb-ft (N•m)
Capscrews:	0.31" - 24	18 - 24 (24 - 33)
	0.50" - 13	85 - 115 (115 - 156)
Stud Nuts: (plain nuts)	0.44" - 20	50 - 75 (68 - 102)
	0.50" - 20	75 - 115 (102 - 156)
	0.56" - 18	110 - 165 (149 - 224)
	0.62" - 18	150 - 230 (203 - 312)
	0.75" - 16	310 - 400 (420 - 542)
(locknut)	0.44" - 20	40 - 65 (54 - 88)
	0.50" - 20	65 - 100 (88 - 136)
	0.56" - 18	100 - 145 (136 - 197)
	0.62" - 18	130 - 190 (176 - 258)
	0.75" - 16	270 - 350 (366 - 475)

8. Unlock (disengage) the DCDL by removing the manual engaging capscrew from the shift assembly.
9. Install the manual engaging capscrew into the storage hole. The storage hole of threaded shift assemblies is located in the shift tower of the carrier next to the cylinder. Tighten to 15-25 lb-ft (20-35 N•m). **Figure 1.** 
10. Connect the air hose to the shift cylinder. Tighten to 22-30 lb-ft (30-40 N•m.) 
11. Install the remaining axle shaft(s) into the axle housing and carrier. Follow Steps 5-7.
12. Check the lubricant level in the axles and hubs where the axle shafts were removed. Add the correct type and amount of lubricant if necessary. For information about lubrication, refer to the Meritor Maintenance Manual 1, *Preventive Maintenance and Lubrication*, or refer to the lubrication section of the Meritor maintenance manual for the axle model you are working with.



Meritor Heavy Vehicle Systems, LLC
2135 West Maple Road
Troy, MI 48084 U.S.A.
866-OnTrac1 (668-7221)
meritor.com

Information contained in this publication was in effect at the time the publication was approved for printing and is subject to change without notice or liability. Meritor Heavy Vehicle Systems, LLC, reserves the right to revise the information presented or to discontinue the production of parts described at any time.

Copyright 2009
Meritor Automotive, Inc.
All Rights Reserved

Printed in the USA
Please Recycle

TP-9579B
Revised 12-09
16579

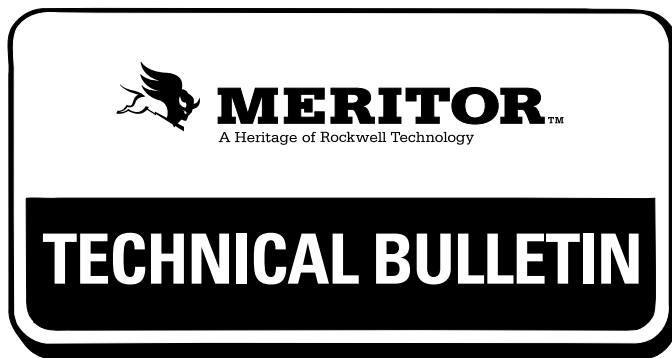

Axle Preparation Instructions for Vehicle Towing or New Vehicle Drive-Away (Piggybacking)

TYPE OF AXLE:

SINGLE AXLE, with Driver Controlled Main Differential Lock (DCDL — bolt on shift assembly)

TANDEM AXLE, with Driver Controlled Main Differential Lock (DCDL — bolt on shift assembly), with Inter-Axle Differential (IAD)

ADDITIONAL AXLE PREPARATION INSTRUCTIONS:

Single and Tandem Axles without DCDL, and Tandem with IAD — Refer to Technical Bulletin, TP-9579A

Single and Tandem Axles with DCDL, Threaded Shift Assembly — Refer to Technical Bulletin, TP-9579B

These instructions are for vehicles equipped with Meritor single or tandem rear drive axles.

The instructions supersede all other instructions for the purpose of transporting vehicles for service or new vehicle drive-away dated before April 1995, including those contained in Meritor maintenance manuals.

When transporting a vehicle with the wheels of one or both drive axles on the road, it is possible to damage the axles if the wrong procedure is used before transporting begins. Meritor recommends that you use the following procedure.

Before Towing or Drive-Away (Piggybacking)



WARNING

To prevent serious eye injury, always wear safe eye protection when you perform vehicle maintenance or service.



WARNING

Engage the parking brake to prevent the vehicle from moving before you begin maintenance or service procedures that require you to be under the vehicle. Serious personal injury can result.

1. Apply the vehicle parking brakes using the switch inside the cab of the vehicle.
2. Shift the transmission into neutral and start the vehicle's engine.
3. Shift the DCDL to the unlocked (disengaged) position using the switch inside the cab of the vehicle. The DCDL indicator light in the cab will go off. Shift the IAD to the unlocked (disengaged) position using the switch inside the cab of the vehicle. The IAD indicator light in the cab will go off (if equipped).
4. Stop the engine.
5. Refer to Table A and identify which axle shafts must be removed based on how the vehicle will be towed.

Table A

Single Axles
Remove both axle shafts.
Tandem Axles
Forward Axle (Towing from Front): No need to remove axle shafts.
Forward Axle (Towing from Rear): Remove both axle shafts.
Rear Axle (Towing from Front): Remove both axle shafts.
Rear Axle (Towing from Rear): No need to remove axle shafts.

6. On axles equipped with a DCDL, the shift collar splines must be engaged with the differential case splines before removing the axle shaft. Engage the DCDL shift collar using the Manual Engaging Method as follows.

CAUTION

On single and tandem rear axles equipped with a DCDL, when removing the curb-side (right) axle shaft, the DCDL shift collar splines must be engaged with the differential case splines. The collar splines must be completely engaged with the differential case splines. This must be done to prevent the shift collar from dropping out of position when removing the axle shaft. Cage (engage) the shift collar with the differential case before removing the axle shaft or damage to components can result.

- a. Disconnect the air hose from the shift cylinder. **Figure 1.**

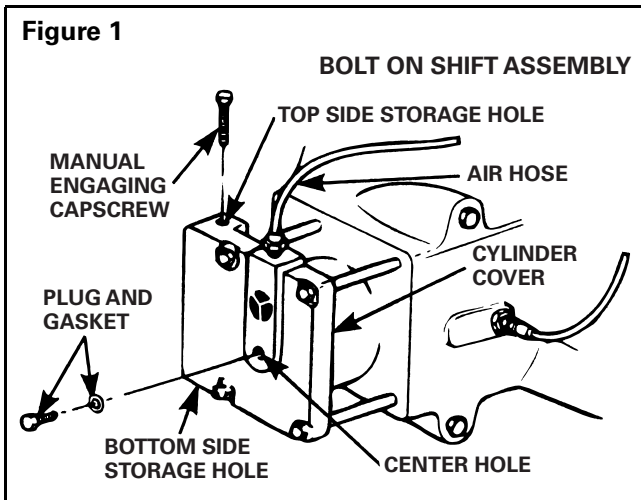

- b. Remove the manual engaging capscrew from the storage hole. The storage hole of threaded shift assemblies is located in the shift tower of the carrier, next to the cylinder. **Figure 1.**
- c. Install the manual engaging capscrew into the threaded hole in the center of the cylinder. **Figure 2.**

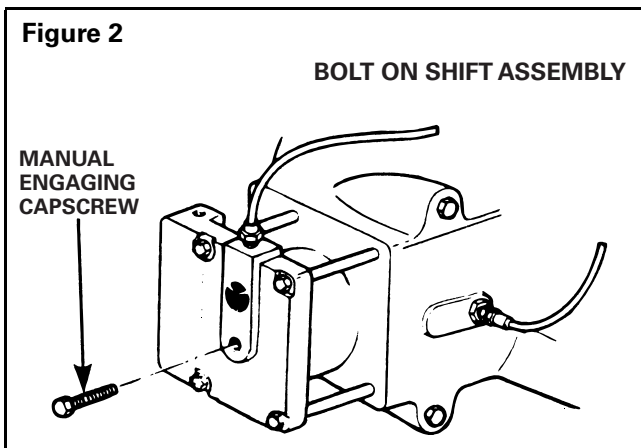

CAUTION

When you turn the capscrew in Step d and you feel a high resistance, STOP TURNING THE CAPSCREW. A high resistance against the capscrew indicates that the splines of the shift collar and differential case are not aligned. Damage to the threads of the cylinder and capscrew will result. To align the splines, continue with Steps e and f.

- d. Turn the capscrew to the right until the head is approximately 0.25 to 0.50-inch (6.4 to 12.7 mm) from the cylinder. The capscrew is now in the service position and the DCDL shift collar is locked (engaged). **Figure 3.** When turning the capscrew you will feel a small amount of resistance. This is normal. If you feel a high resistance before achieving the 0.25- to 0.50-inch distance between the capscrew head and cylinder, **STOP TURNING THE CAPSCREW** and continue with Steps e and f.

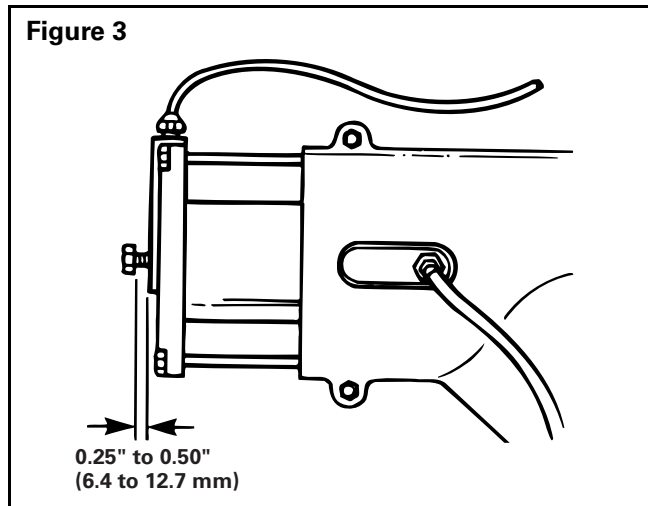

- e. Raise the tire and wheel (DCDL axle side) off of the floor (leave the opposite tire and wheel on the floor) and support the axle with jack stands. Slowly rotate the wheel of the DCDL axle shaft that is to be removed by hand.
- f. Verify that the clutch collar is engaged by attempting to rotate the elevated wheel. If it does not rotate, the collar is successfully caged. The axle shaft can now be removed.
 - **If you still feel a high resistance:** Stop turning the capscrew, disassemble and inspect components for damage and wear. Replace as necessary.

7. Identify each axle shaft so they can be installed in the same location after transporting or repair is completed. (Example: Match mark a mating axle shaft and hub.)
8. Remove the stud nuts or capscrews and the washers from the flange of the axle shaft. **Figure 4.**
9. Loosen the tapered dowels, if used, in the flange of the axle shaft using one of the two following methods. **Figure 4.**

CAUTION

Do not use a chisel or wedge to loosen the axle shaft and dowels. The chisel or wedge can damage the hub, axle shaft and gasket, if used.

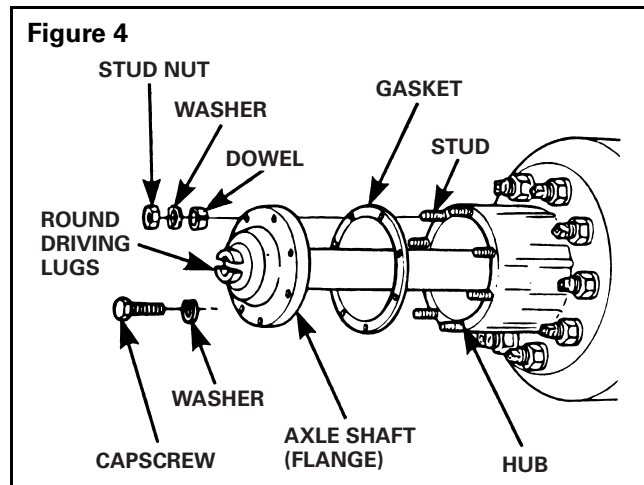

Brass Drift Method:

WARNING

Do not strike the round driving lugs on the flange of an axle shaft. Pieces can break off and cause serious personal injury.

NOTE: A 1.5-inch (38.1 mm) diameter brass hammer can be used as a drift.

- a. Hold a 1.5-inch (38.1 mm) diameter brass drift against the center of the axle shaft flange, **INSIDE THE ROUND DRIVING LUGS**. **Figure 5.**

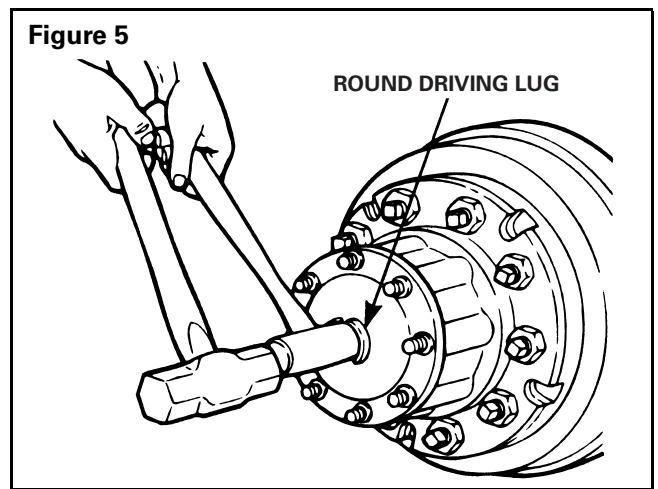

- b. Hit the end of the drift with a large hammer (5 to 6 pounds, 2.3 to 2.7 kg) to loosen the axle shaft and tapered dowels from the hub. **Figure 5.**

Air Hammer Method:

WARNING

To prevent serious eye injury, always wear safe eye protection when you perform vehicle maintenance or service.

- a. Use an air hammer, such as Chicago Pneumatic CP-4181-PULER, or equivalent, with a round hammer bit to loosen the axle shaft and dowels.
- b. Put the round hammer bit against the axle shaft flange between the studs, at different points around the flange. Operate the air hammer at each location and loosen the axle shaft and tapered dowels from the hub. **Figure 6.**

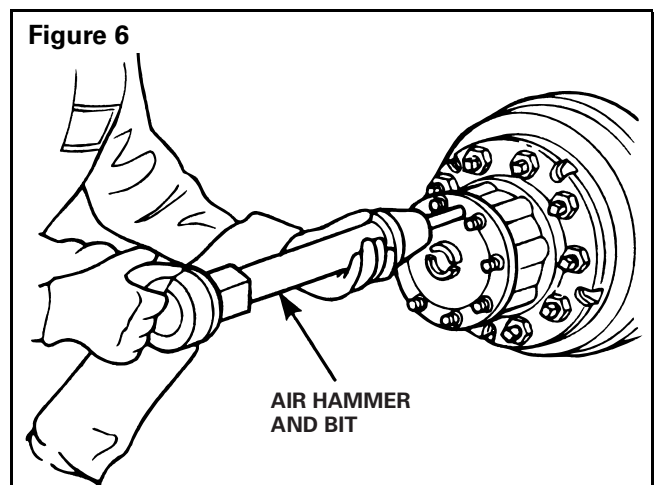

10. Remove the tapered dowels, the axle shafts and gaskets (if used). **Figure 4.**
11. Remove the remaining axle shaft(s) as necessary from the axle(s) that will remain on the road when the vehicle is transported according to Table A.
12. Install a cover over the open end of each hub where an axle shaft was removed. This will prevent dirt from entering the bearing cavity and minimize loss of lubricant.

NOTE: If an air supply will be used for the brake system of the transported vehicle, continue with Steps 13 and 14, otherwise continue with Step 15.

13. Connect an auxiliary air supply to the brake system of the vehicle that is being transported. Before moving the vehicle, charge the brake system with the correct amount of air pressure to operate the brakes. Refer to the instructions supplied by the manufacturer of the vehicle for procedures and specifications. If an auxiliary air supply is not used, continue with Step 15.
14. When the correct amount of air pressure is in the brake system, release the parking brakes of the vehicle that is being transported. Step 15 is not required.



WARNING

When you work on a spring chamber, carefully follow the service instructions of the chamber manufacturer. Sudden release of a compressed spring can cause serious personal injury.

15. If there are spring (parking) brakes on the axle(s) that will remain on the road when the vehicle is transported, and they cannot be released by air pressure, manually compress and lock each spring so that the brakes are released. Refer to the manufacturer's instructions.

After Towing or Drive-Away (Piggybacking)



WARNING

To prevent serious eye injury, always wear safe eye protection when you perform vehicle maintenance or service.



WARNING

Engage the parking brake to prevent the vehicle from moving before you begin maintenance or service procedures that require you to be under the vehicle. Serious personal injury can result.

1. If an auxiliary air supply was used, apply the vehicle parking brakes using the switch inside the cab of the vehicle. If an auxiliary air supply was not used, begin with Step 2.



WARNING

When you work on a spring chamber, carefully follow the service instructions of the chamber manufacturer. Sudden release of a compressed spring can cause serious personal injury.

2. Apply the vehicle spring (parking) brakes by manually releasing each spring that was compressed before transporting started. Refer to manufacturer's instructions.
3. Disconnect the auxiliary air supply, if used, from the brake system of the vehicle that was transported. Connect the vehicle's air supply to the brake system.
4. Remove the covers from the hubs.

NOTE: Install the axle shafts indicated in **Table B**. Axle shafts with a DCDL have a double row of splines that engage with splines of the side gear and of the shift collar in the differential case. **Figure 7.** Continue with Step 5.

Table B

Single Axles
Remove both axle shafts.
Tandem Axles
Forward Axle (Towing from Front): No need to remove axle shafts.
Forward Axle (Towing from Rear): Remove both axle shafts.
Rear Axle (Towing from Front): Remove both axle shafts.
Rear Axle (Towing from Rear): No need to remove axle shafts.

NOTE: Make sure to engage the axle shaft splines for the differential side gear and the shift collar. They must be fully engaged.

5. Install the gasket, if used, and axle shaft into the axle housing and carrier in the same location it was removed from. The gasket and flange of the axle shaft must be flat against the hub. Rotate the axle shaft and/or the driveline as necessary to align the splines and the holes in the flange with the studs in the hub. **Figure 4.**
6. Install the dowels, if used, over each stud and into the tapered holes of the flange.

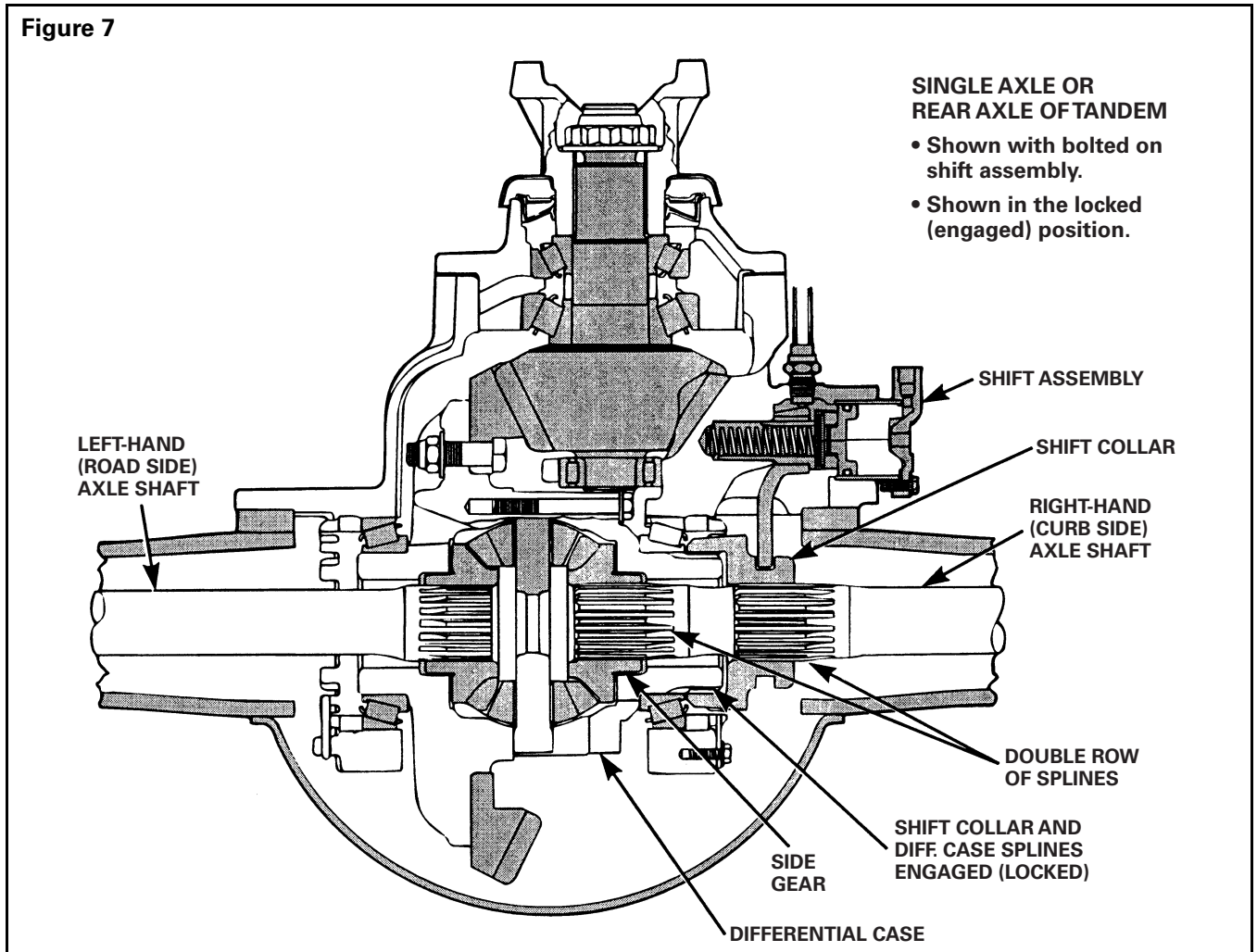

Figure 7



7. Install the washers and capscrews or stud nuts. Determine the size of the fasteners and tighten the capscrews or nuts to the corresponding torque value shown in **Table C**.

Table C

	Thread Size	Torque Value lb-ft (N•m) 
Capscrews:	0.31" - 24	18 - 24 (24 - 33)
	0.50" - 13	85 - 115 (115 - 156)
Stud Nuts: (plain nuts)	0.44" - 20	50 - 75 (68 - 102)
	0.50" - 20	75 - 115 (102 - 156)
	0.56" - 18	110 - 165 (149 - 224)
	0.62" - 18	150 - 230 (203 - 312)
	0.75" - 16	310 - 400 (420 - 542)
(locknut)	0.44" - 20	40 - 65 (54 - 88)
	0.50" - 20	65 - 100 (88 - 136)
	0.56" - 18	100 - 145 (136 - 197)
	0.62" - 18	130 - 190 (176 - 258)
	0.75" - 16	270 - 350 (366 - 475)

8. Unlock (disengage) the DCDL by removing the manual engaging capscrew from the shift assembly.
9. Install the manual engaging capscrew into the storage hole. The storage hole of bolted on shift assemblies is located in the top side of the shift cylinder cover. Tighten to 15-25 lb-ft (20-35 N•m). **Figure 1.** 
10. Remove the plug and gasket from the storage hole. Install the plug and gasket into the threaded hole in the center of the shift cylinder cover. Tighten to 15-25 lb-ft (20-35 N•m). 
11. Install the remaining axle shaft(s) into the axle housing and carrier. Follow Steps 5-7.
12. Check the lubricant level in the axles and hubs where the axle shafts were removed. Add the correct type and amount of lubricant if necessary. For information about lubrication, refer to the Meritor Maintenance Manual 1, *Preventive Maintenance and Lubrication*, or refer to the lubrication section of the Meritor maintenance manual for the axle model you are working with.



MERITOR[™]
A Heritage of Rockwell Technology

Meritor Heavy Vehicle Systems, LLC
2135 West Maple Road
Try, MI 48084 USA
800-535-5560
arvinmeritor.com

Information contained in this publication was in effect at the time the publication was approved for printing and is subject to change without notice or liability. Meritor Heavy Vehicle Systems, LLC, reserves the right to revise the information presented or to discontinue the production of parts described at any time.

Copyright 2009
Meritor Automotive, Inc.
All Rights Reserved

Printed in the USA
Please Recycle

TP-9579C
Revised 12-09
16579/22882



TECHNICAL BULLETIN

Installing the Meritor Driver Controlled Main Differential Lock (DCDL)

All Single and Tandem Drive Axles

The driver controlled differential lock is operated by an air actuated shift assembly that is mounted on the carrier. **Figure 1.** When the differential lock is engaged, the shift collar is moved along the splines of the axle shaft toward the differential case. When the splines on the shift collar are engaged with the splines on the differential case, the axle shafts and differential assembly are locked together.

- When the carrier operates with the differential lock **ENGAGED**, there is no differential action between the wheels of the axle.

- When the carrier is operated with the differential lock **DISENGAGED**, there is normal differential action between the wheels of the axle at all times.

The differential lock is available on many Meritor single axles and on one or both axles of certain tandem drive axles.

Figure 1

STANDARD CARRIER WITH DIFFERENTIAL LOCK (DCDL)

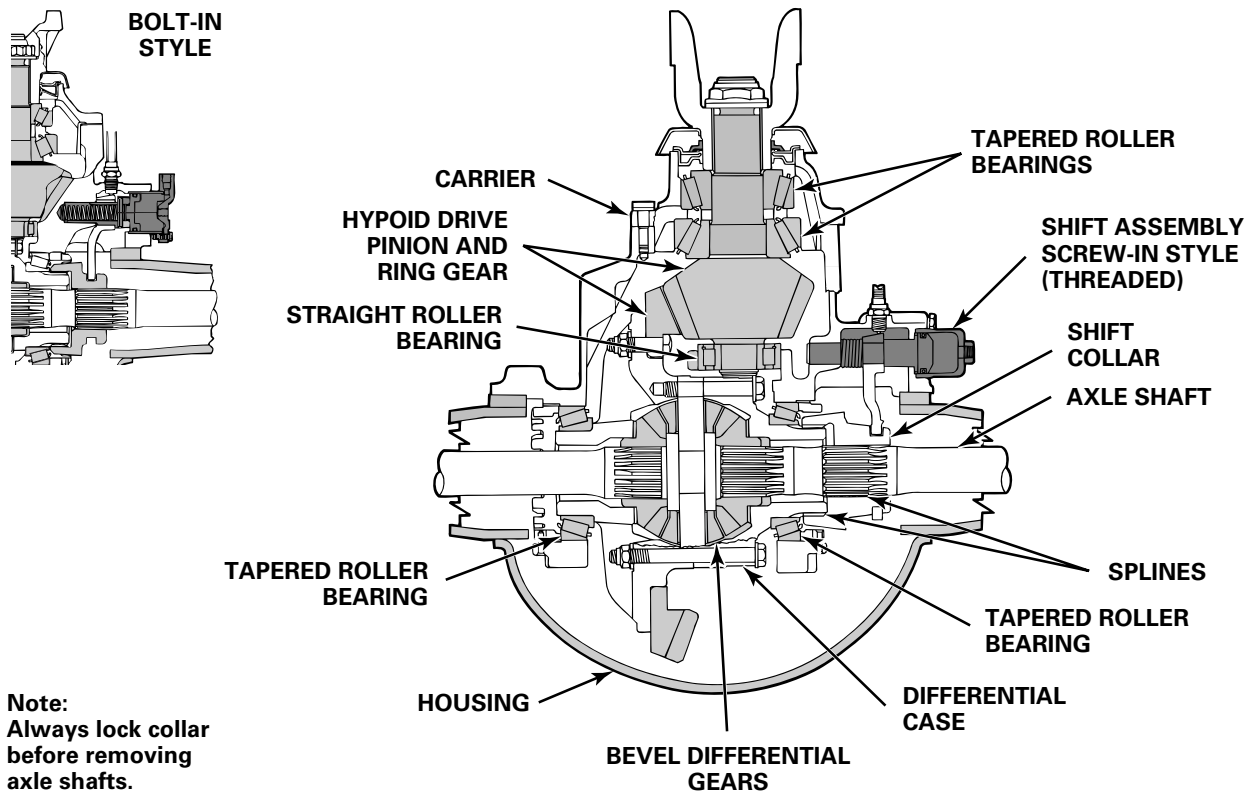

Installation in Vehicle

The differential lock shift unit **MUST** be connected correctly to the other vehicle components to ensure that the axle and the main differential lock system operate properly. Meritor recommends connecting the air line from the shift unit **through the low speed range of the air shifted transmission. Figure 2.**

1. Connect a fused wire from the power supply (ignition/battery) to the differential lock indicator light in the vehicle cab. We recommend a separate indicator light for each differential lock-equipped axle of a tandem.
2. Connect the indicator light to one wire of the sensor/switch in each of the axle carriers with the differential lock.
3. Ground the indicator light circuit(s) by connecting the second wire of the sensor/switch to the chassis.
4. Connect an air line from the control side of the transmission low range control valve to the supply side of the driver control plunger. The plunger must be the type that is held in by air pressure and automatically releases when the air pressure is discontinued. Use a Midland valve KNZ 0031, KNZ 0033 or equivalent.
5. Connect an air line from the delivery side of the plunger to the control side of the axle air control valve.
6. Connect an air line from the delivery side of the axle air control valve to the differential lock actuator on each of the axles with the differential lock.
7. Connect an air line from the air supply tank to the supply side of the air control valve.
8. Connect an air line from the air supply tank to the supply side of the transmission low range control valve.

WARNING

To prevent serious eye injury, always wear safe eye protection when you perform vehicle maintenance or service.

WARNING

*Do not connect together or combine the control systems on tandem axles that have both inter-axle differential locks and main differential locks. Each locking system **MUST** be capable of being operated independently of each other. Damage to components and serious personal injury can result.*

NOTE: Any other main differential lock installation procedures **MUST** be approved by Meritor Heavy Vehicle Systems, LLC, Axle Engineering, Troy, Michigan.

Figure 2

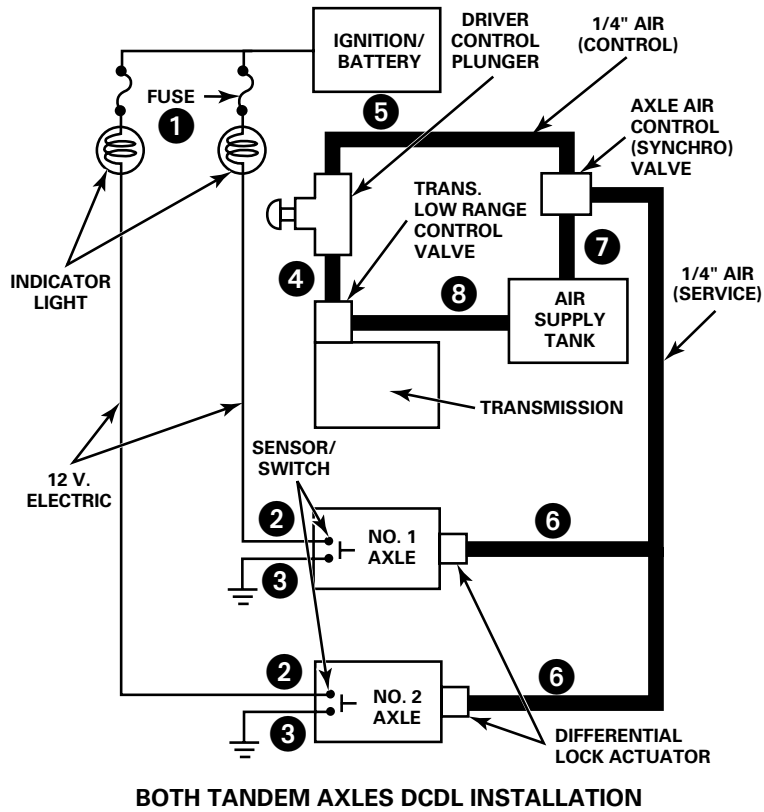
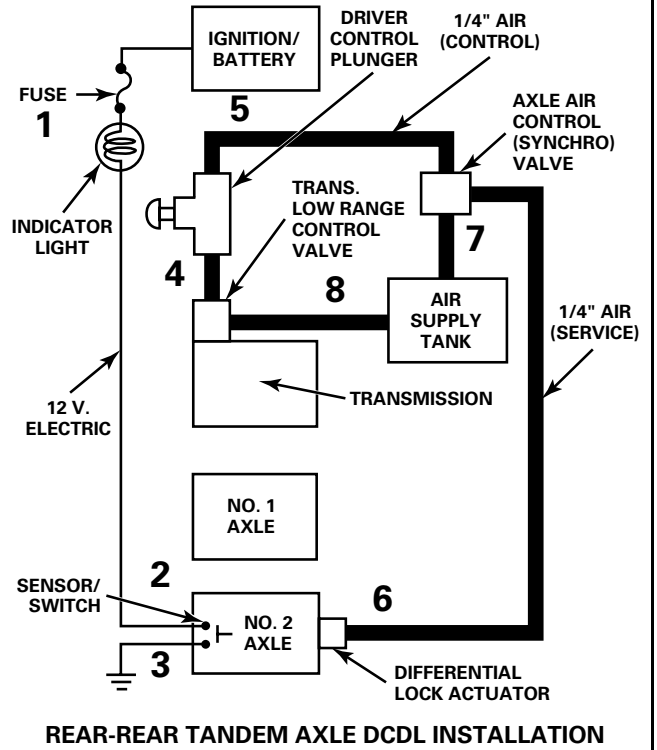
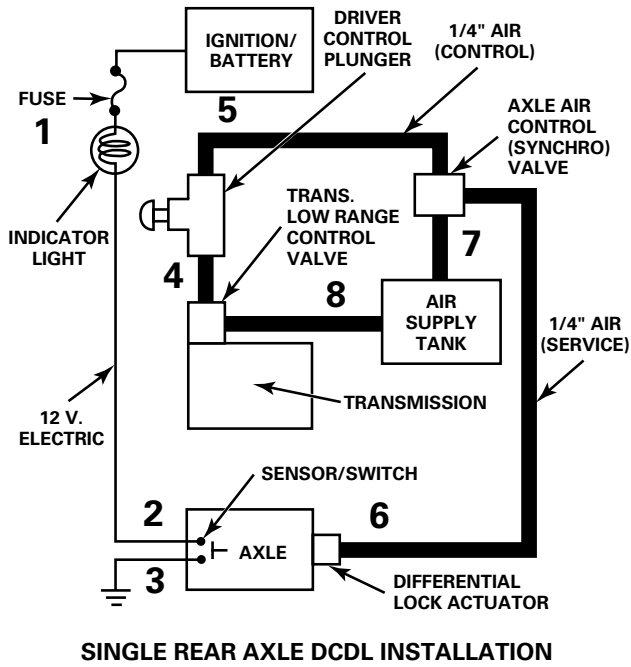



MERITOR™
A Heritage of Rockwell Technology

Meritor Heavy Vehicle Systems, LLC
2135 West Maple Road
Try, MI 48084 U.S.A.
800-535-5560
www.meritorauto.com

Information contained in this publication was in effect at the time the publication was approved for printing and is subject to change without notice or liability. Meritor Heavy Vehicle Systems, LLC, reserves the right to revise the information presented or to discontinue the production of parts described at any time.

Copyright 1997
Meritor Automotive, Inc.
All Rights Reserved

Printed in the USA
Please Recycle

TP-9781
Issued 4-97
16579/22882



Meritor Heavy Vehicle Systems, LLC
2135 West Maple Road
Troy, MI 48084 USA
866-OnTrac1 (668-7221)
meritor.com

Information contained in this publication was in effect at the time the publication was approved for printing and is subject to change without notice or liability. Meritor Heavy Vehicle Systems, LLC, reserves the right to revise the information presented or discontinue the production of parts described at any time.

Copyright 2018
Meritor, Inc.
All Rights Reserved

Printed in the USA

TP-9579
Revised 11-18
16579