

Maintenance Manual MM-0146

Transfer Cases

MTC-4208, -4210 and -4213

Revised 12-08

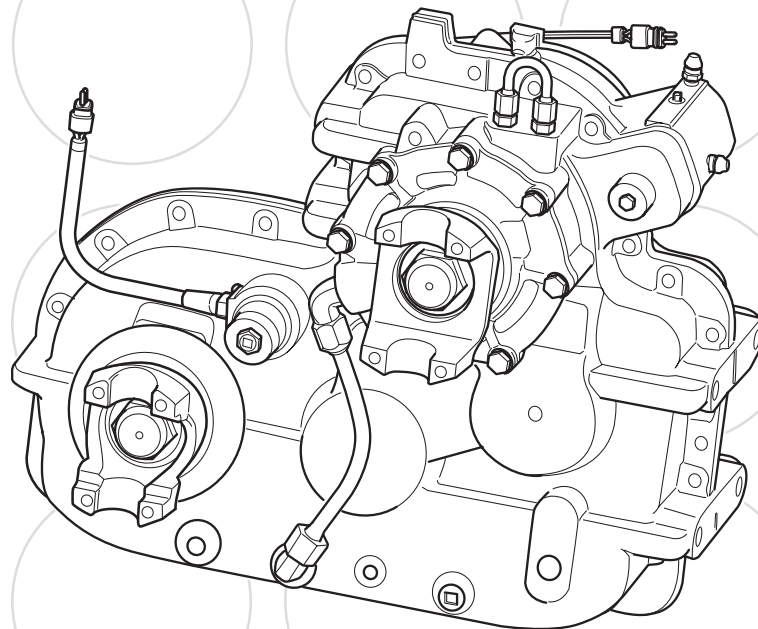

Service Notes

About This Manual

This manual provides maintenance and service procedures for the Meritor MTC-4208, -4210 and -4213 transfer cases.

Before You Begin

1. Read and understand all instructions and procedures before you begin to service components.
2. Read and observe all Warning and Caution hazard alert messages in this publication. They provide information that can help prevent serious personal injury, damage to components, or both.
3. Follow your company's maintenance and service, installation, and diagnostics guidelines.
4. Use special tools when required to help avoid serious personal injury and damage to components.

Hazard Alert Messages and Torque Symbols

WARNING

A Warning alerts you to an instruction or procedure that you must follow exactly to avoid serious personal injury and damage to components.

CAUTION

A Caution alerts you to an instruction or procedure that you must follow exactly to avoid damage to components.

 This symbol alerts you to tighten fasteners to a specified torque value.

How to Obtain Additional Maintenance and Service Information

On the Web

Visit Literature on Demand at meritorhvs.com to access product, service, aftermarket, and warranty literature for ArvinMeritor's truck, trailer and specialty vehicle components.

ArvinMeritor's Customer Service Center

Call ArvinMeritor's Customer Service Center at 800-535-5560.

Technical Electronic Library DVD

The DriveTrain Plus™ by ArvinMeritor Technical Electronic Library DVD contains product and service information for most Meritor and Meritor WABCO products. Specify TP-9853.

How to Obtain Tools and Supplies Specified in This Manual

Call ArvinMeritor's Commercial Vehicle Aftermarket at 888-725-9355 to obtain Meritor tools and supplies.

Information contained in this publication was in effect at the time the publication was approved for printing and is subject to change without notice or liability. Meritor Heavy Vehicle Systems, LLC, reserves the right to revise the information presented or to discontinue the production of parts described at any time.

pg. 1	Section 1: Exploded Views MTC-4208 Transfer Case Rear Cover MTC-4208 Transfer Case Front Case	pg. 34	Input Bearing Cage and Oil Pump Assembly Installation, Bearing End Play Adjustment and Transfer Case Final Assembly
2	MTC-4210 Transfer Case Rear Cover	35	Transfer Case Shifting Check
3	MTC-4210 Transfer Case Front Case	36	Adjust the Oil Level
4	MTC-4213 Transfer Case Rear Cover		Transfer Case Assembly Test
5	MTC-4213 Transfer Case Front Case	37 Section 7: Power Take-Off (PTO)	
6	MTC-4208 and -4210 Declutch/PTO		Installation
7 Section 2: Introduction	Model Nomenclature Meritor Transfer Case — Model Nomenclature	39	Remove the Transfer Case Rear Access Cover
8	Description	40	Install the Yoke Onto the PTO
9	Operation Front Axle Declutch (If Equipped)		Install the Optional Indicator Switch
10	Oil Cooler Option Blow-by Breather	41	Install the PTO Onto the Transfer Case
11	Full-Torque Power Take-Off (PTO) Breather Location		Test the PTO Installation
12 Section 3: Removal	Remove the Transfer Case Assembly	42	Test the Transfer Case with the PTO Assembly Installed PTO Assembly
14 Section 4: Disassembly	Disassemble the Transfer Case Front and Rear Output Yokes Front Input Shaft, Input Bearing Cage and Pump Assembly	45 Section 8: Installation	Install the Transfer Case Check and Adjust the Oil Level
17	Front Input Shaft, Input Shaft Bearing Cage and Oil Pump	46 Section 9: Diagnostics	Troubleshooting Transfer Case Lubrication Diagnostics
18	Idler Gear Shaft Optional PTO Assembly on MTC-4208 and -4210 Transfer Cases	48	Excessive Noise and Vibration Diagnostics
19 Section 5: Prepare Parts for Assembly	Clean, Dry and Inspect Parts Ground and Polished Parts Parts with a Rough Finish Transfer Case Assemblies Dry Cleaned Parts Prevent Corrosion	49	PTO Does Not Engage/Disengage Diagnostics
20	Inspect Parts	50	Front Axle Declutch Does Not Engage/Disengage Diagnostics
23	Preparing the Case and Cover and Seal Replacement	51	High/Low Gear Shifting Diagnostics
24 Section 6: Assembly	Assemble the Transfer Case	52 Section 10: Lubrication and Maintenance	How to Obtain Additional Lubrication and Maintenance Information Lubricant Temperatures Meritor MTC-4208, MTC-4209 and MTC-4210 Series Transfer Cases Do Not Install API GL-5 Oils Petroleum-Base and Multi-Viscosity Oils Operating Information Magnets and Magnetic Drain Plugs Breather
26	Adjustment MTC-4213 Rear Output Shaft End Play MTC-4208 and -4210 Rear Output Shaft End Play	53	Seals Special Tools and Installation Procedure
27	Idler Shaft Bearing End Play	54	Check and Adjust the Oil Level Drain and Replace the Oil
28	Front Output Shaft End Play	55	Inspection Meritor MTC-4208, -4210 and -4213 Transfer Case Inspection
29	Assembly High and Low Shifter	57 Section 11: Specifications	Torque Specifications
30	Front Axle Shifter	58 Section 12: Vehicle Towing Instructions	Guidelines
31	Front Input Shaft, Input Shaft Bearing Cage and Oil Pump Assembly	59 Section 13: Special Tools	Tool Drawing
32	Input Seal Installation		

1 Exploded Views

MTC-4208 Transfer Case Rear Cover

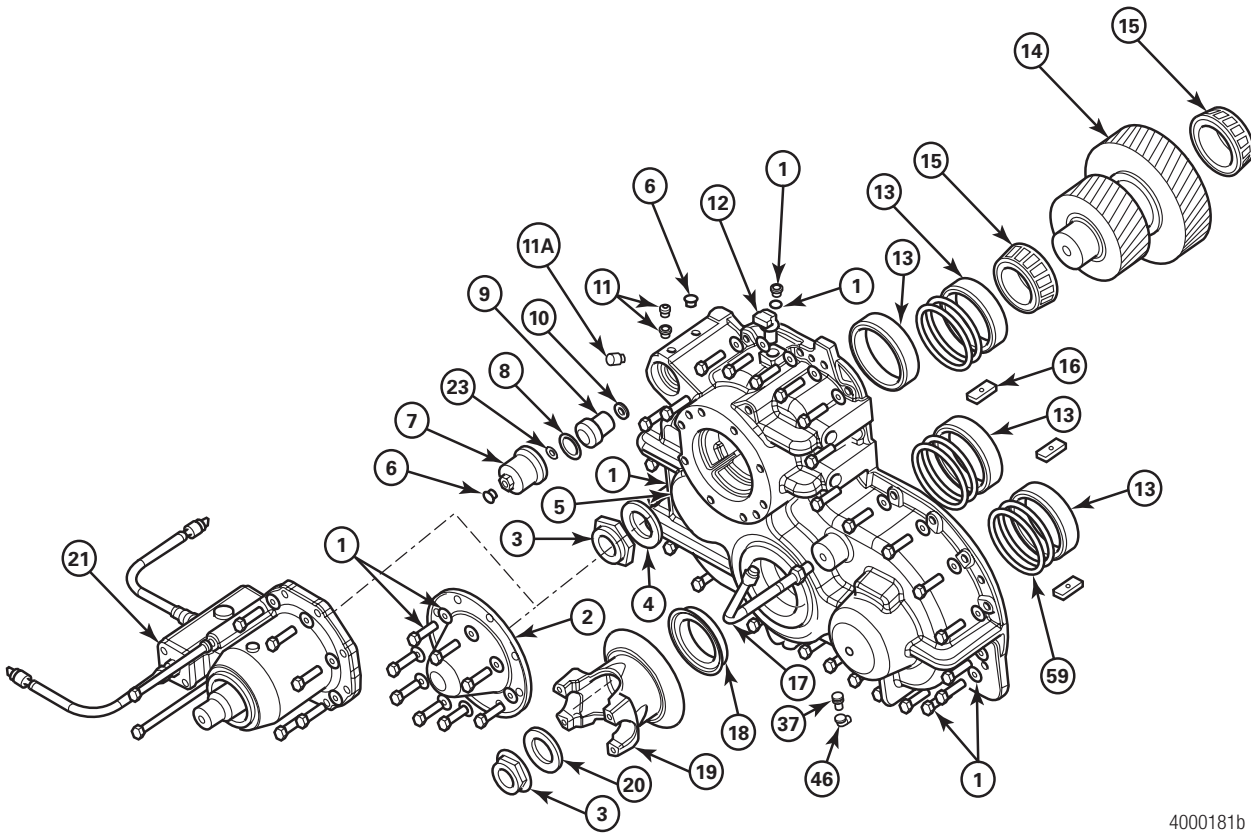

4000181b

Item	Description
1	Capscrew and Washer
2	Cover
3	Locknut
4	Hardened Washer
5	Transfer Case Rear Cover
6	Shipping Protector
7	Shift Cylinder
8	Shift Piston O-Ring
9	Shift Piston
10	O-Ring
11	Neutral Breather*
11A	Blow-by Breather
12	Speed Sensor
13	Bearing Cup
14	Idler Gear
15	Bearing Cone
16	Ceramic Magnet
17	Switch Assembly
18	Rear Output Oil Seal

Item	Description
19	Rear Output Yoke
20	Flat Washer
21	Optional PTO Assembly
22	Driven Gear and Rear Output Shaft
23	Snap Ring
24	Shift Shaft
25	Input Shaft
26	Special Orifice Plug
27	Shift Fork Capscrew
28	Shift Fork
29	Helical Drive Gear, High Range
30	High and Low Clutch Collar
31	Helical Drive Gear, Low Range
32	Snap Ring
33	Transfer Case Front Case

* Vehicles not equipped with a transfer case neutral air control may be equipped with a neutral breather which allows the shift cavity to exhaust. On vehicles equipped with a neutral air control, the solenoid allows this cavity to exhaust.

MTC-4208 Transfer Case Front Case

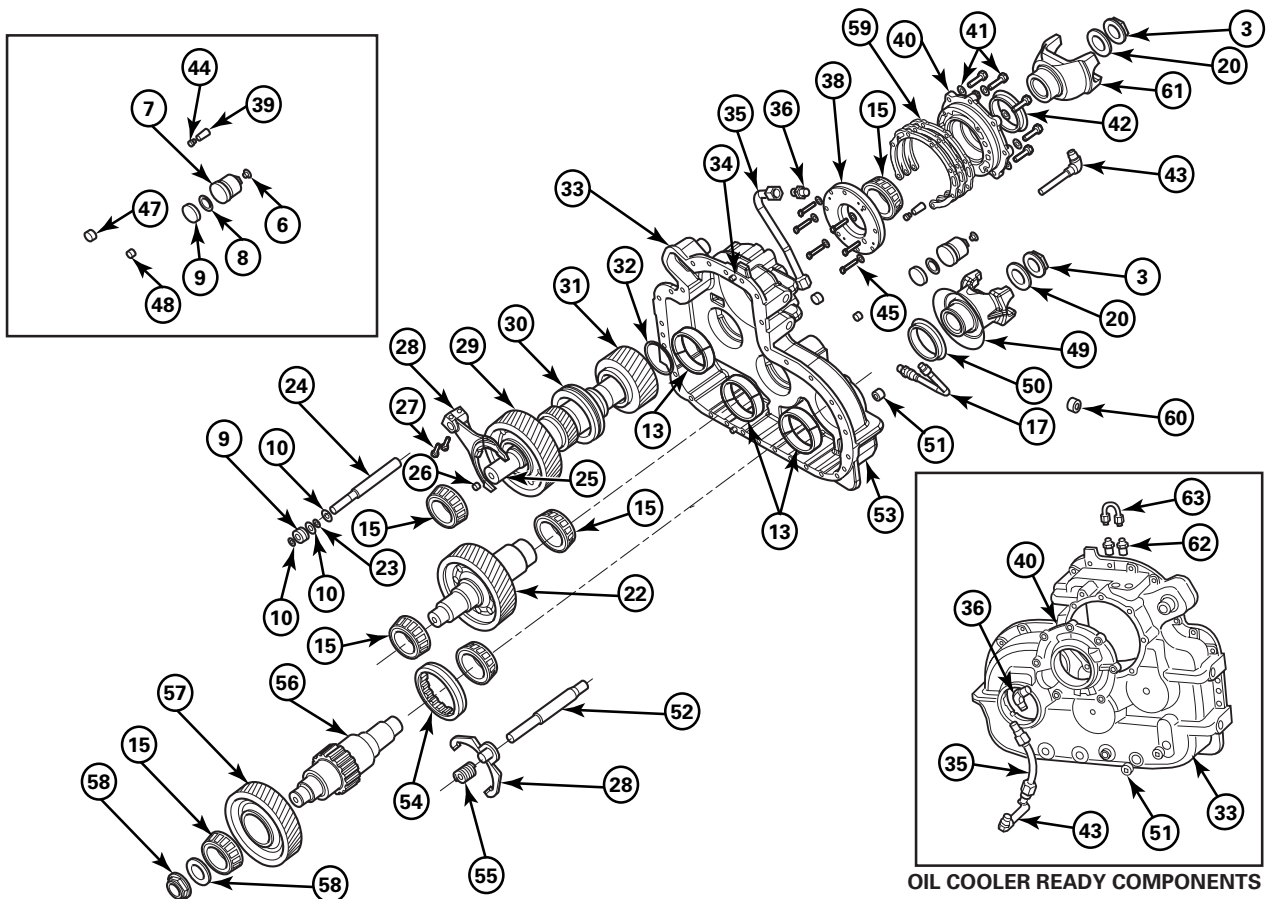

OIL COOLER READY COMPONENTS

4000181a

Item	Description
34	Locating Dowel Pin
35	Inlet Oil Tube Assembly
36	Male Fitting
37	Breather Assembly
38	Oil Pump Assembly
39	Relief Valve Spring
40	Input Bearing Cage
41	Bearing Cage Capscrew and Washer
42	Input Oil Seal
43	Oil Fitting Assembly
44	Relief Valve
45	Oil Pump Capscrew and Washer
46	Elbow
47	Oil Fill Plug
48	3/8-Inch Plug

Item	Description
49	Front Output Yoke
50	Front Output Oil Seal
51	Drain Plug
52	Push Rod
53	Locating Dowel Pin
54	Front Output Clutch Collar
55	Spring
56	Front Output Shaft
57	Helical Driven Gear
58	Locknut and Flat Washer
59	Shim
60	Plug
61	Input Yoke
62	Oil Cooler Male Connector
63	Loop Tube

1 Exploded Views

MTC-4210 Transfer Case Rear Cover

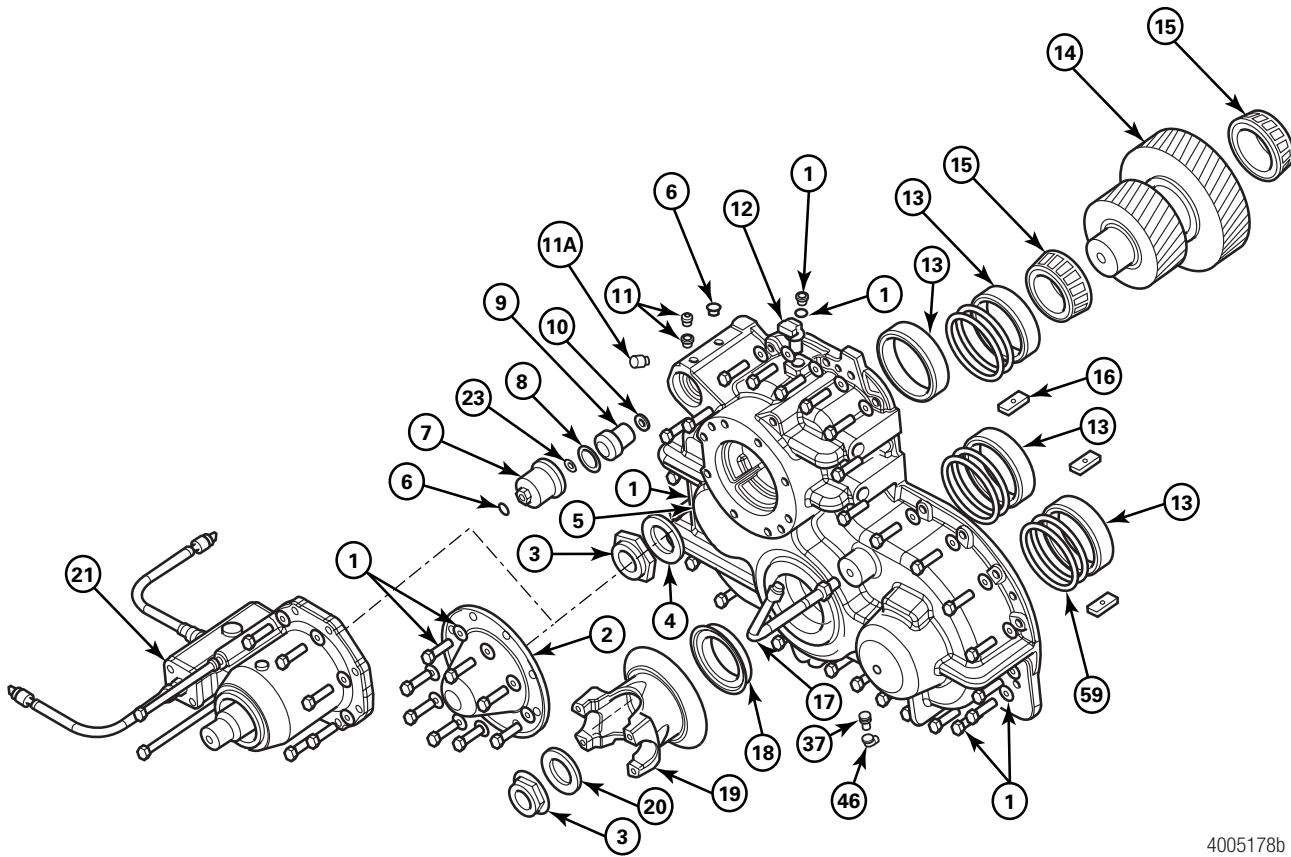

4005178b

Item	Description
1	Capscrew and Washer
2	Cover
3	Locknut
4	Hardened Washer
5	Transfer Case Rear Cover
6	Shipping Protector
7	Shift Cylinder
8	Shift Piston O-Ring
9	Shift Piston
10	O-Ring
11	Neutral Breather*
11A	Blow-by Breather
12	Speed Sensor
13	Bearing Cup
14	Idler Gear
15	Bearing Cone
16	Ceramic Magnet
17	Switch Assembly
18	Rear Output Oil Seal

Item	Description
19	Rear Output Yoke
20	Flat Washer
21	Optional PTO Assembly
22	Driven Gear and Rear Output Shaft
23	Snap Ring
24	Shift Shaft
25	Input Shaft
26	Special Orifice Plug
27	Shift Fork Capscrew
28	Shift Fork
29	Helical Drive Gear, High Range
30	High and Low Clutch Collar
31	Helical Drive Gear, Low Range
32	Snap Ring
33	Transfer Case Front Case

* Vehicles not equipped with a transfer case neutral air control may be equipped with a neutral breather which allows the shift cavity to exhaust. On vehicles equipped with a neutral air control, the solenoid allows this cavity to exhaust.

MTC-4210 Transfer Case Front Case

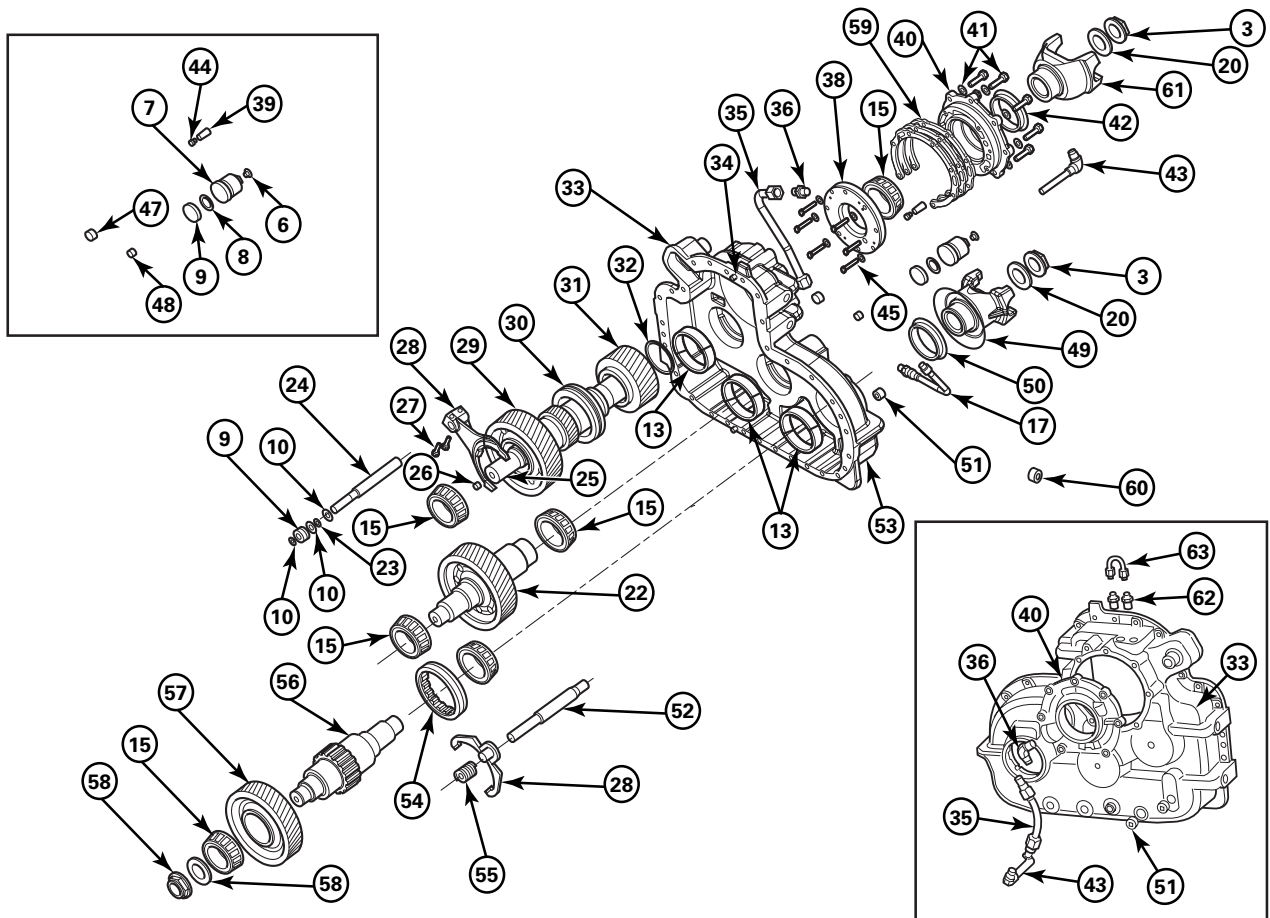

OIL COOLER READY COMPONENTS

4005178a

Item	Description
34	Locating Dowel Pin
35	Inlet Oil Tube Assembly
36	Male Fitting
37	Breather Assembly
38	Oil Pump Assembly
39	Relief Valve Spring
40	Input Bearing Cage
41	Bearing Cage Capscrew and Washer
42	Input Oil Seal
43	Oil Fitting Assembly
44	Relief Valve
45	Oil Pump Capscrew and Washer
46	Elbow
47	Oil Fill Plug
48	3/8-Inch Plug

Item	Description
49	Front Output Yoke
50	Front Output Oil Seal
51	Drain Plug
52	Push Rod
53	Locating Dowel Pin
54	Front Output Clutch Collar
55	Spring
56	Front Output Shaft
57	Helical Driven Gear
58	Locknut and Flat Washer
59	Shim
60	Plug
61	Input Yoke
62	Oil Cooler Male Connector
63	Loop Tube

1 Exploded Views

MTC-4213 Transfer Case Rear Cover

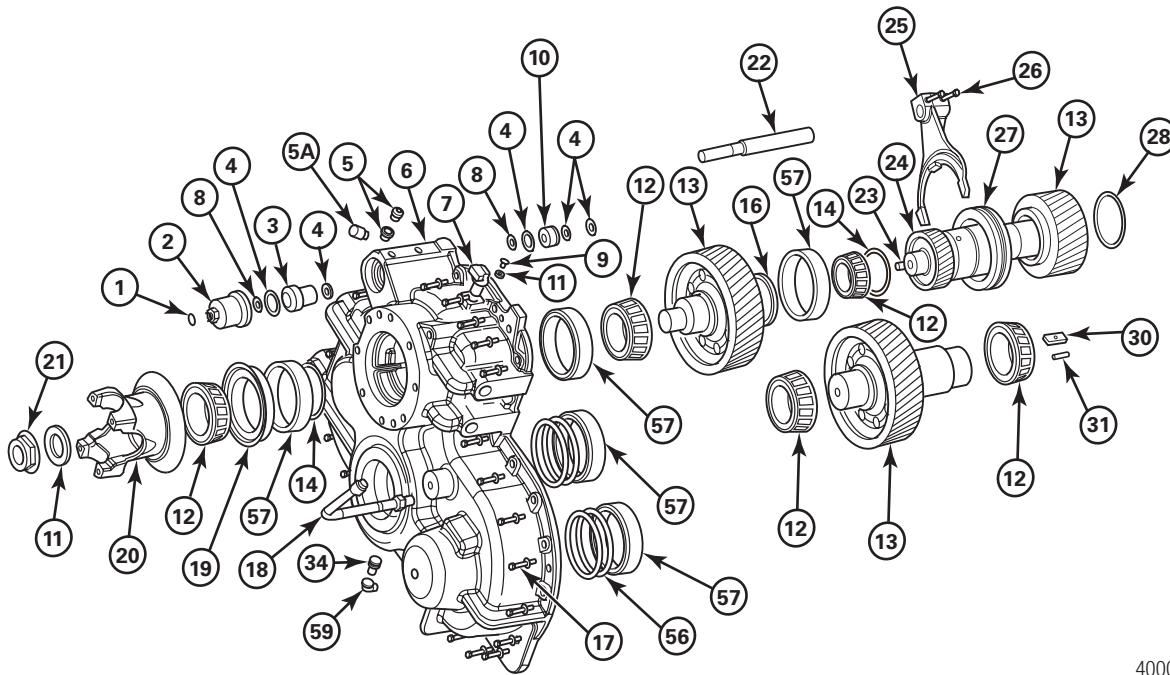

4000180b

Item	Description
1	Shipping Protector
2	Shift Cylinder
3	Outer Shift Piston
4	O-Ring
5	Neutral Breather ¹
5A	Blow-by Breather
6	Transfer Case Rear Cover
7	Speed Sensor
8	Snap Ring
9	Capscrew
10	Inner Shift Piston
11	Flat Washer
12	Bearing Cone
13	Idler Gear 2
14	Spacer ²
15	Idler Gear 1
16	Rear Output Shaft
17	Cover-to-Case Capscrew
18	Switch Assembly

Item	Description
19	Rear Output Oil Seal
20	Rear Output Yoke
21	Locknut
22	High and Low Shift Shaft
23	Special Plug
24	Input Shaft
25	High and Low Shift Fork
26	Shift Fork Capscrew
27	High and Low Clutch Collar
28	Snap Ring
29	Transfer Case Front Case
30	Ceramic Magnet
31	Locating Dowel Pin
32	Inlet Oil Tube Assembly
33	Male Fitting

¹ Because the MTC-4213 model is not equipped with neutral capability, the neutral shift port may be plugged with a breather that allows the shift cavity to exhaust.

² Use as needed. Refer to Parts Catalog PB-0229, MTC-4213 Transfer Case, for usage.

MTC-4213 Transfer Case Front Case

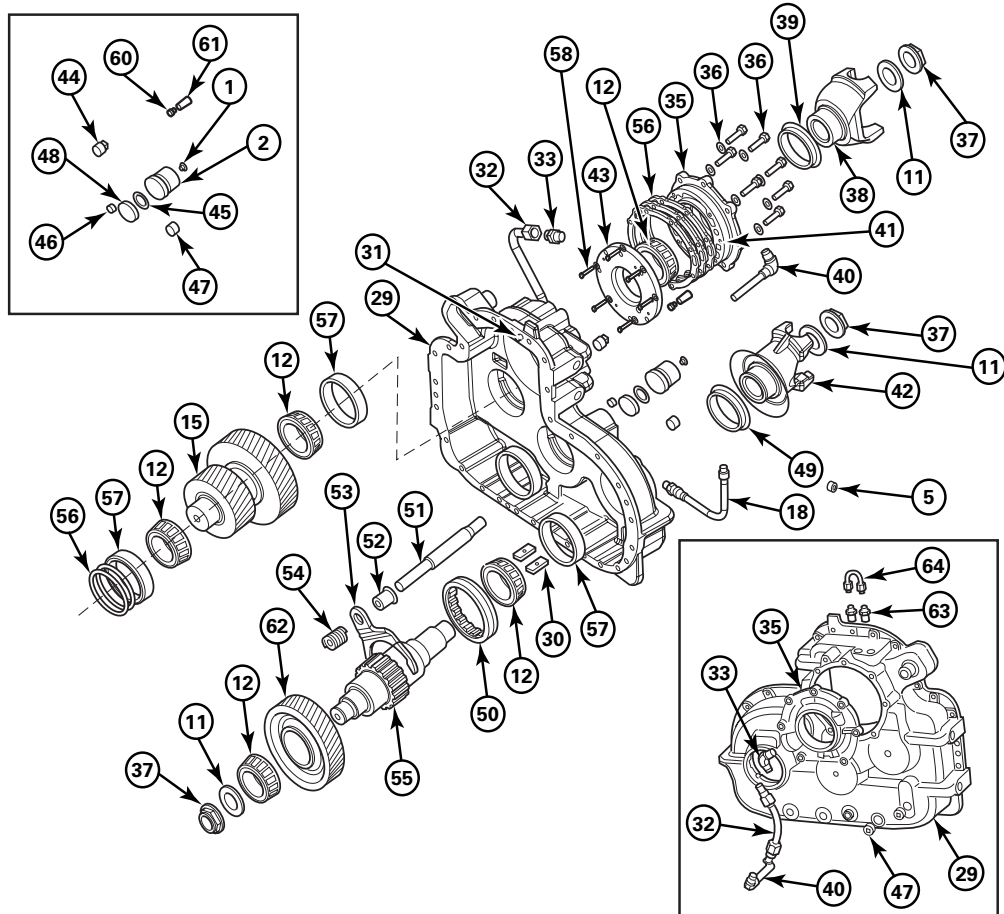

OIL COOLER READY COMPONENTS
4000180a

Item	Description
34	Breather Assembly
35	Input Bearing Cage
36	Bearing Cage Capscrew and Washer
37	Locknut
38	Input Yoke
39	Input Oil Seal
40	Oil Fitting Assembly
41	Input Bearing Cage O-Ring
42	Front Output Yoke
43	Oil Pump Assembly
44	Oil Fill Plug
45	Shift Piston O-Ring
46	3/8-Inch Plug
47	Drain Plug
48	Shift Piston
49	Front Output Oil Seal

Item	Description
50	Front Output Clutch Collar
51	Push Rod
52	Shift Fork Tube
53	Front Output Shift Fork
54	Spring
55	Front Output Shaft
56	Shim
57	Bearing Cup
58	Oil Pump Capscrew and Washer
59	Elbow
60	Relief Valve
61	Relief Valve Spring
62	Helical Drive Gear
63	Oil Cooler Male Connector
64	Loop Tube

1 Exploded Views

MTC-4208 and -4210 Declutch/PTO

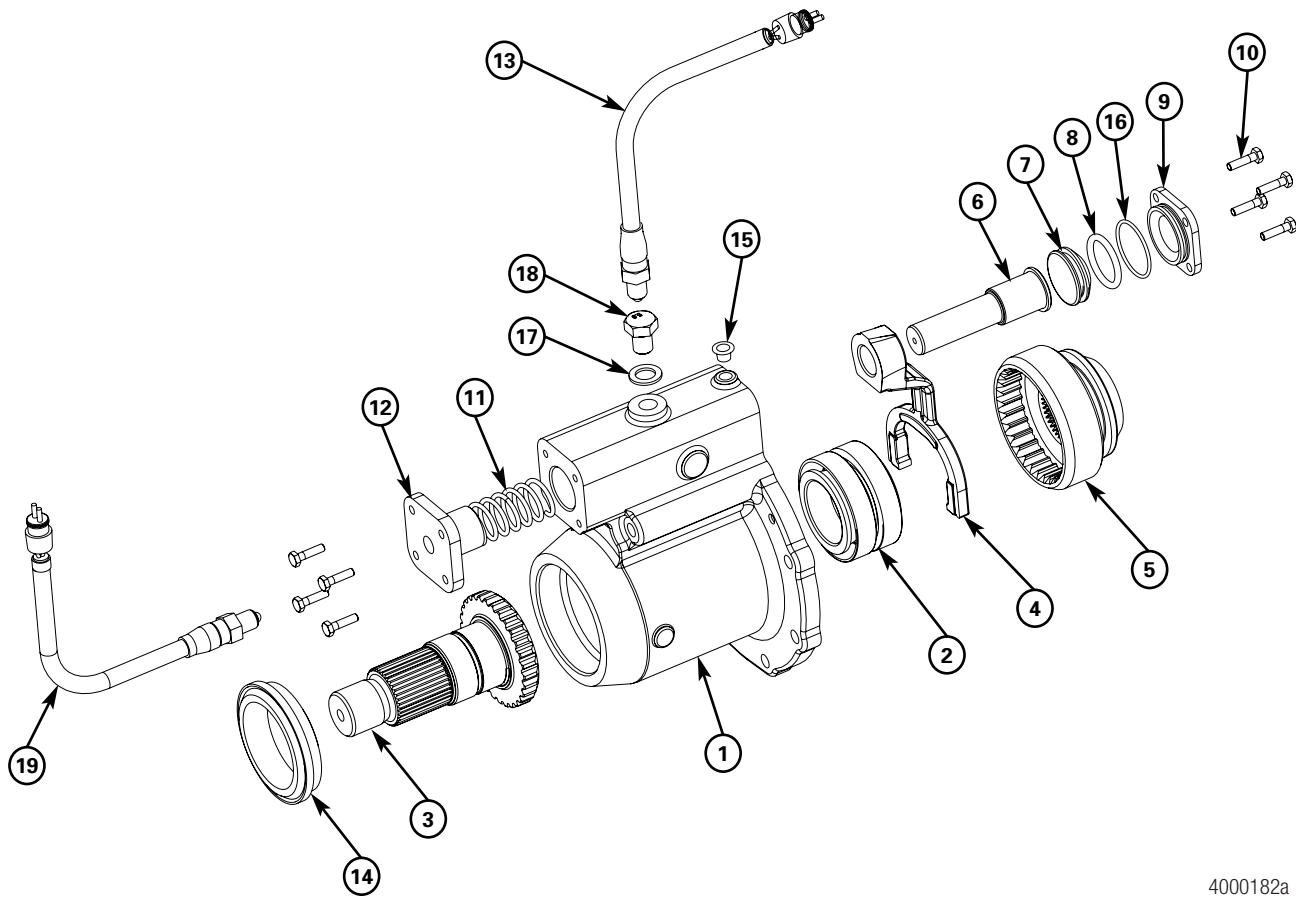

4000182a

Item	Description
—	Declutch Assembly
1	Bearing Cage
2	Bearing Assembly
3	PTO Shaft
4	Shift Fork
5	Clutch Collar
6	Push Rod
7	Shifter Piston
8	O-Ring
9	Cover Plate
10	Capscrew
11	Shifter Spring
12	Cap

Item	Description
13	Connector Switch Assembly — Disengage, Optional
14	Oil Seal Assembly
15	Shipping Protector
16	O-Ring
17	Flat Washer
18	Special Screw
19	Connector Switch Assembly — Engage

Model Nomenclature

Meritor Transfer Case — Model Nomenclature

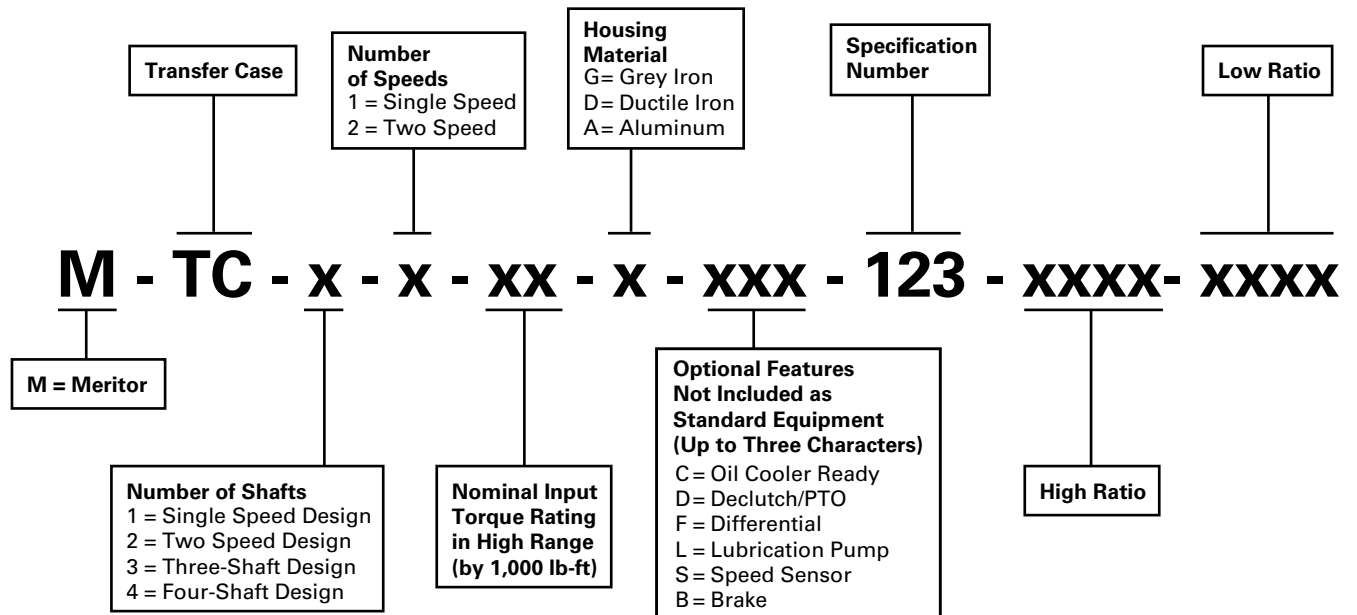

4001531b

Transfer case model nomenclature is illustrated in the following example.

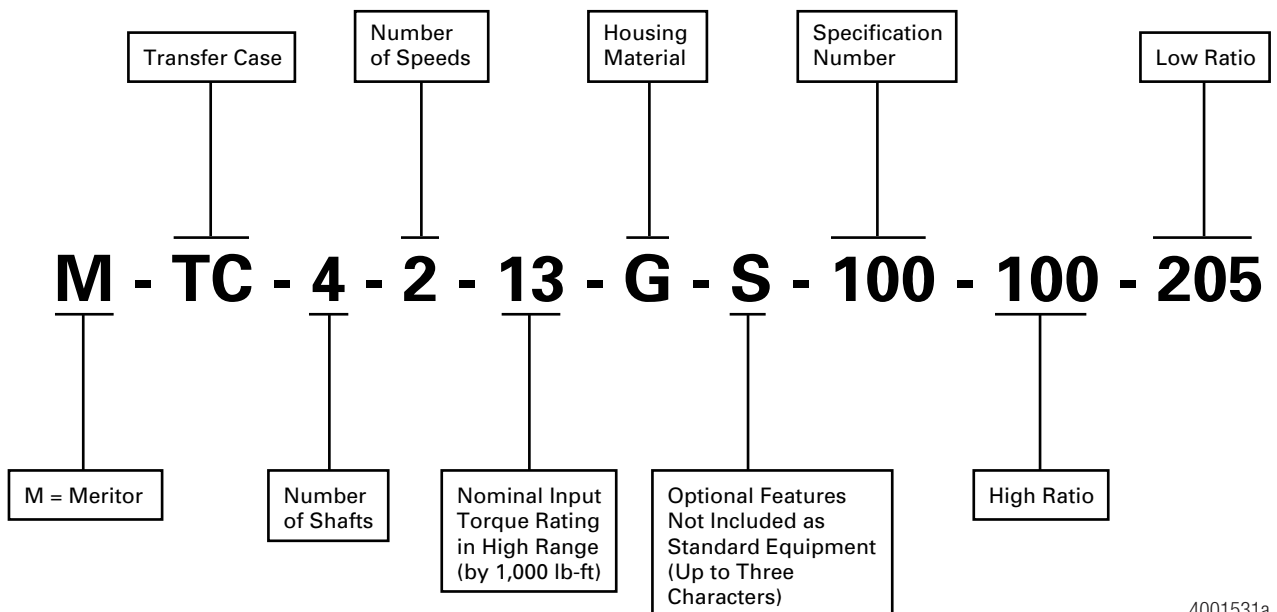

4001531a

2 Introduction

Description

Meritor MTC-4208, -4210 and -4213 transfer cases are four-shaft designs with two-speed front and rear output having a 1:1 and a 1:2.05 ratio for use with 4x4 and 6x6 vehicles. The MTC-4208 and -4210 are designed specifically for use in 4x4 vehicles (the MTC-4213 is designed specifically for 6x6) as part of the Meritor medium-duty 4x4 system. Figure 2.1.

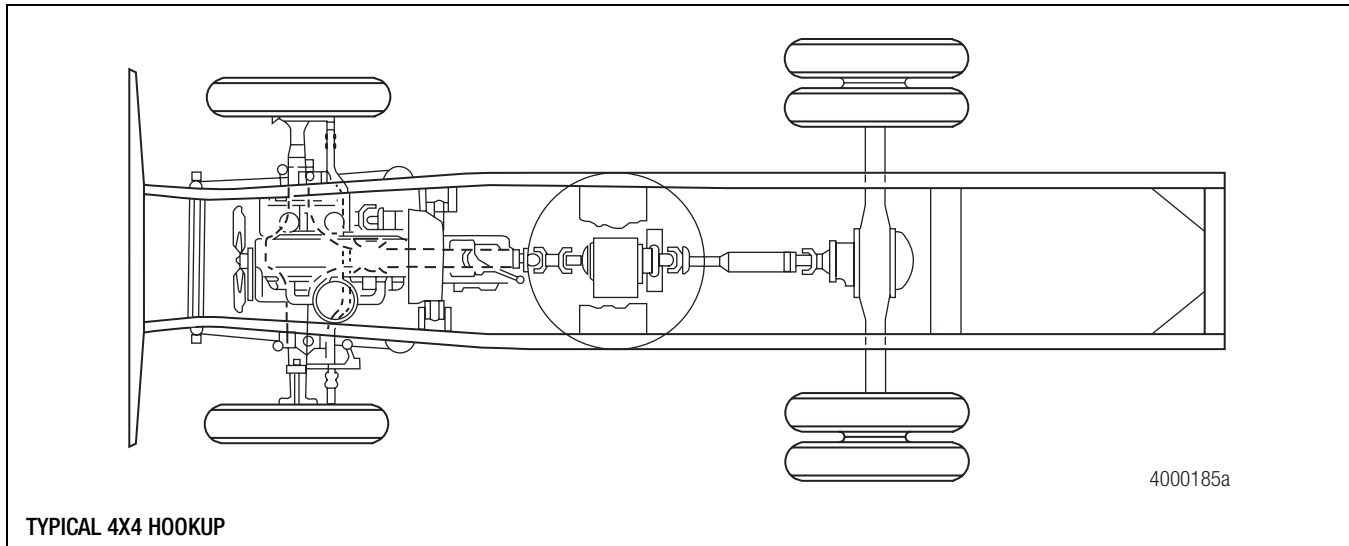

TYPICAL 4X4 HOOKUP

Figure 2.1

The air-actuated front-axle declutch (if equipped), high and low shifter and full-torque power take-off (PTO) lockup are controlled from the cab. An air plunger or electric switch, usually mounted on the instrument panel, engages or disengages a mechanical clutch.

An optional speed sensor measures transfer case output driveline rpm. Optional switches indicate when the front axle declutch is fully engaged or disengaged.

These transfer cases provide for two-speed output (high range and low range) and a neutral position that is used for PTO-equipped transfer cases only. Non-PTO cases have this neutral position plugged. Figure 2.2.

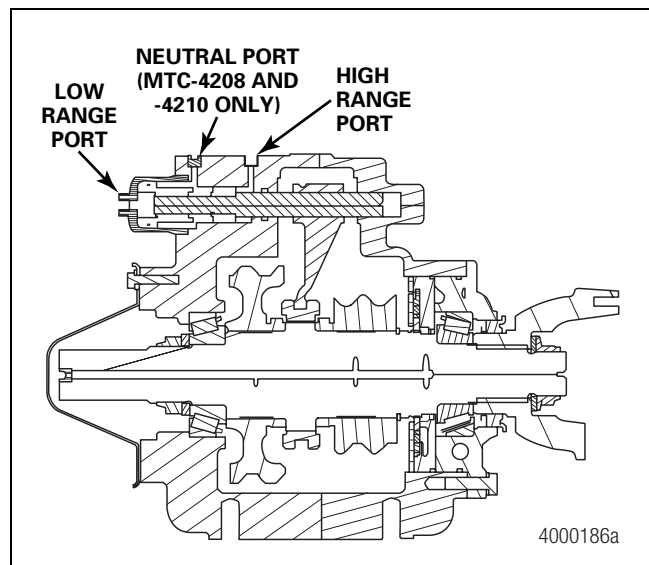

Figure 2.2

The front axle declutch permits shifting from part-time 4x4 or 6x6 to rear-wheel drive (RWD). Figure 2.3.

The full-torque PTO option provides an outlet to drive auxiliary power devices. Figure 2.4.

Optional switches for full-torque PTOs indicate full engagement or disengagement.

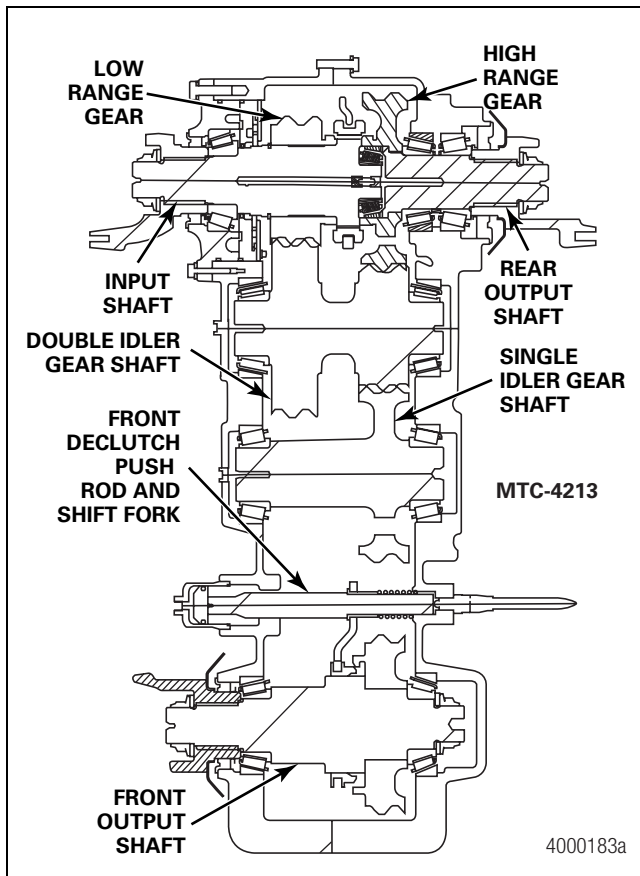

Figure 2.3

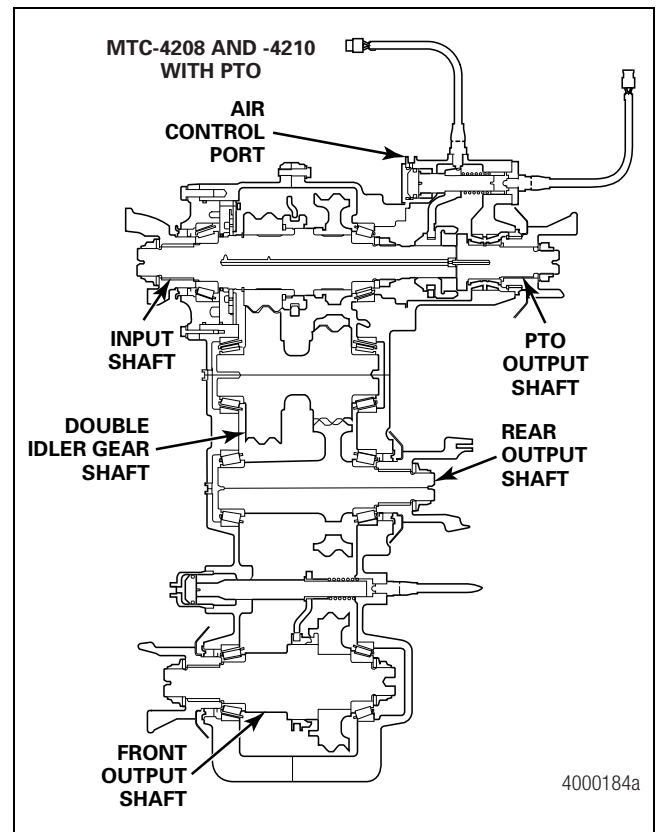

Figure 2.4

Operation

Front Axle Declutch (If Equipped)

⚠ WARNING

Do not engage the front axle declutch when the vehicle's wheels are slipping or when moving up or down a steep hill or grade, which can cause the vehicle to lose stability. Serious personal injury and damage to components can result.

Only engage the front axle declutch under poor operating conditions. The vehicle must be stationary or operating below 10 mph (4 km/h). Engaging the declutch adjusts the vehicle's turning and steering responsiveness. Do not engage the declutch or low gear range under normal operating conditions. Serious personal injury and damage to components can result.

Engage the declutch when the vehicle is stationary or operating at constant low speed, below 10 mph or 4 km/h.

2 Introduction

Shift the transfer case into low from high gear or from high to low gear when the vehicle is stationary. Apply the parking brake with the transmission in Neutral, automatic transmission only.

You will know that engagement occurs by hearing it, noticing improved vehicle performance, or observing the optional indicator light in the cab.

- **If the clutch does not fully engage:** Turn the steering wheel in one direction and rock the vehicle back and forth until engagement occurs.

Oil Cooler Option

Vehicle configuration can have a significant impact on MTC model transfer cases. Vehicles with overdrive transmissions used primarily for high-speed highway routes run at higher transfer case input speeds. Transfer case running temperature is primarily affected by input speed, regardless of rear-wheel-drive only or 4x4/6x6 operation.

A transfer case oil cooler reduces operating temperatures which will improve yoke seal life, reduce oil degradation and reduce the likelihood for other oil and air leaks. Figure 2.5.

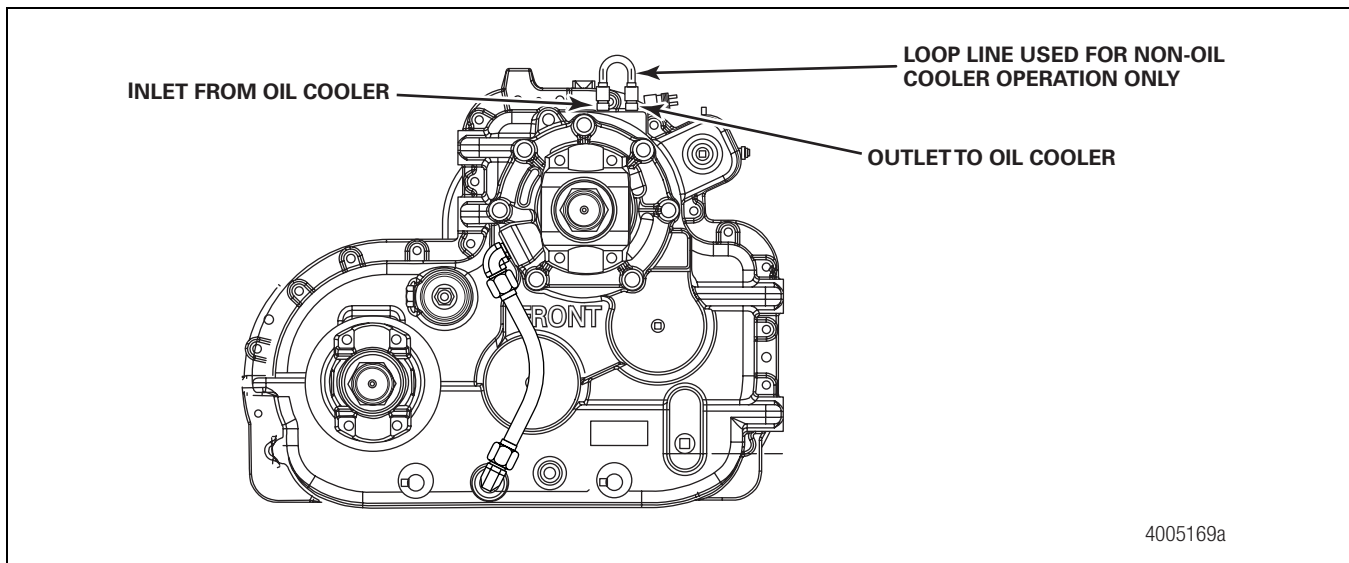

Figure 2.5

An oil cooler may be adaptable to MTC transfer cases with the following designation in the product specification. Product information can be found on the transfer case nameplate located on the front of its housing.

- Part number MTC-4210-GCS-100-100-205 where the "C" stands for "Cooler Ready"
- Part number MTC-4210-GS-100-100-205 is not cooler ready.

The reconfiguration provides the means to divert oil from the transfer case pump out to an oil cooler and return to the shaft oil gallery. A loop line may be used on models that have cooler capability yet do not have an oil cooler connected. Refer to Technical Publication TP-0468, Connecting an Oil Cooler to MTC-4208, -4210 and -4213 Transfer Cases, for further instruction on connecting an oil cooler.

Blow-by Breather

The rear cover portion of the housing on models built fall of 2004 forward is equipped with a blow-by breather. The breather, which points sideways on the driver side of the housing, prohibits pressurization of the housing if an O-ring becomes damaged. Because all range shifts require full time pressurization, a damaged O-ring would allow air to fill the housing which could further damage the yoke seals or blow oil from the housing.

Full-Torque Power Take-Off (PTO)

⚠ CAUTION

Do not engage the full-torque power take-off (PTO) when the transfer case prop shafts are turning. Damage to the transfer case will result.

Engage or disengage the PTO when the vehicle is stationary, the transmission is in Neutral, and the transfer case prop shafts are not turning. Do not load the driven auxiliary device when PTO is initially engaged. Use the transfer case in-cab switches to place the transfer case into Neutral.

You will know that engagement occurs by hearing it, noticing improved vehicle performance, or observing the optional indicator light in the cab.

Breather Location

On older transfer case models, the breather assembly was located on the front case. On current transfer case models, the breather assembly is located on the rear cover. Figure 2.6.

If the breather is found in either of the old positions, it is recommended that the breather be repositioned.

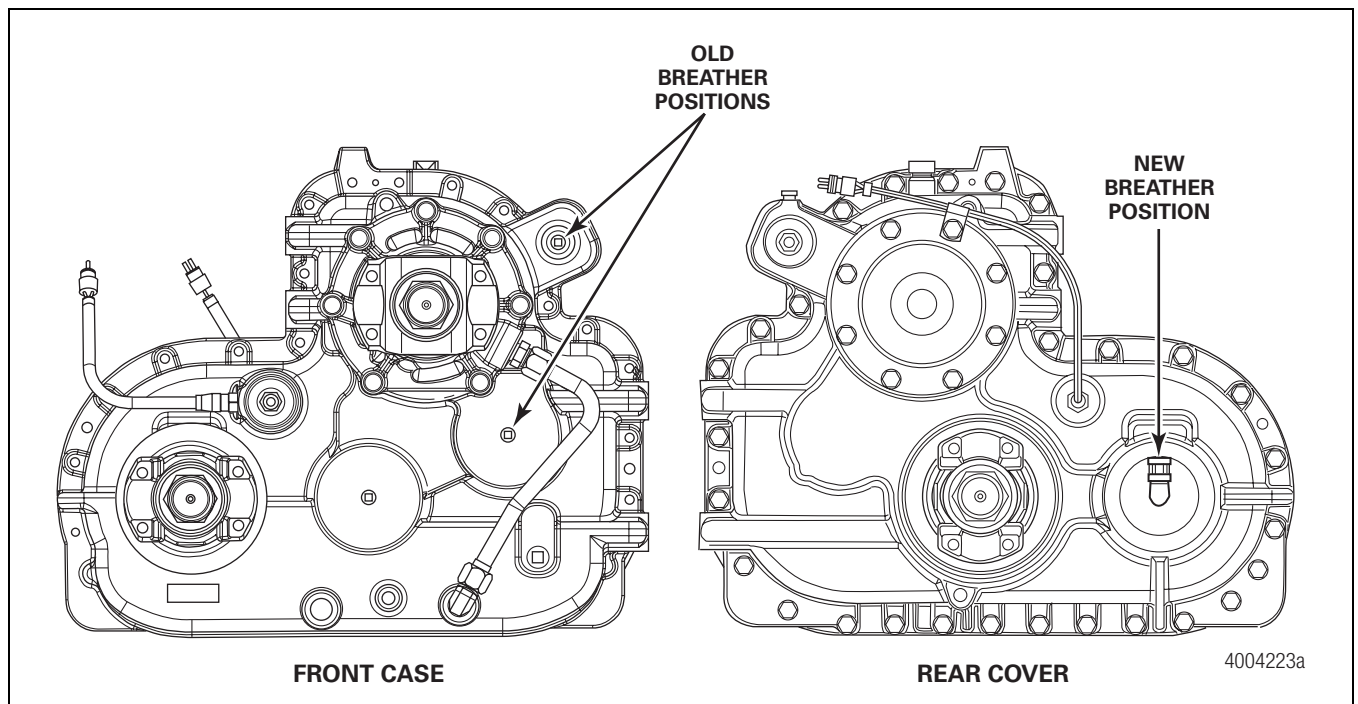

Figure 2.6

3 Removal

Hazard Alert Messages

Read and observe all Warning and Caution hazard alert messages in this publication. They provide information that can help prevent serious personal injury, damage to components, or both.

⚠ WARNING

To prevent serious eye injury, always wear safe eye protection when you perform vehicle maintenance or service.

Park the vehicle on a level surface. Block the wheels to prevent the vehicle from moving. Support the vehicle with safety stands. Do not work under a vehicle supported only by jacks. Jacks can slip and fall over. Serious personal injury and damage to components can result.

Remove the Transfer Case Assembly

1. Park the vehicle on a level surface. Place blocks under the wheels not being raised to keep the vehicle from moving.
2. Raise the vehicle so that the area to be serviced is off the ground. Support the vehicle with safety stands.
3. Place a large container under the transfer case.
4. Remove the magnetic drain plug from the bottom of the transfer case. Drain and discard the oil correctly. Clean the magnetic drain plug. Figure 3.1.

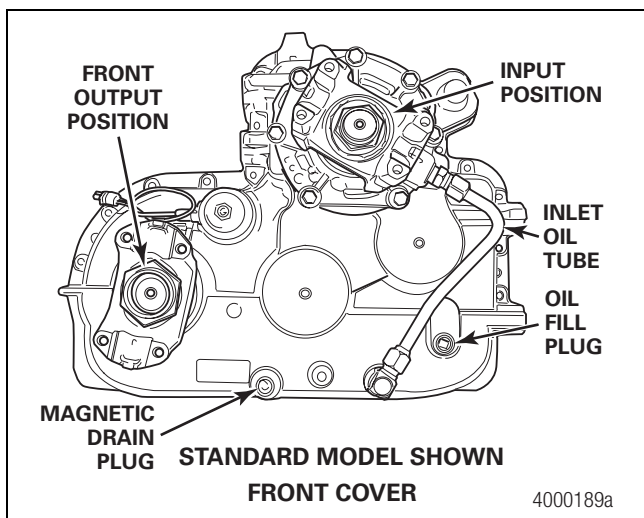

Figure 3.1

5. Disconnect the drivelines from the input and output yokes or flanges of the transfer case.

6. Disconnect the air lines at the shift cylinders of the transfer case.
7. Disconnect the harness for the indicator switch wires.
8. Use a hydraulic roller jack to support the transfer case. Remove the mounting bolts that hold the transfer case to the vehicle.
9. Carefully remove the transfer case with the hydraulic jack.

⚠ CAUTION

Close or cover all openings, including the breather, oil drain and speed sensor, before steam cleaning the outside of the transfer case. Steam can damage components.

10. Close or cover all openings before steam cleaning. These openings include the breather, oil drain and speed sensor.
11. Steam clean the outside of the transfer case to remove heavy amounts of dirt.
12. Construct angle iron brackets or similar fixtures. Attach the brackets to the front half of the transfer case by installing bolts through the mounting holes in the transfer case. Figure 3.2.

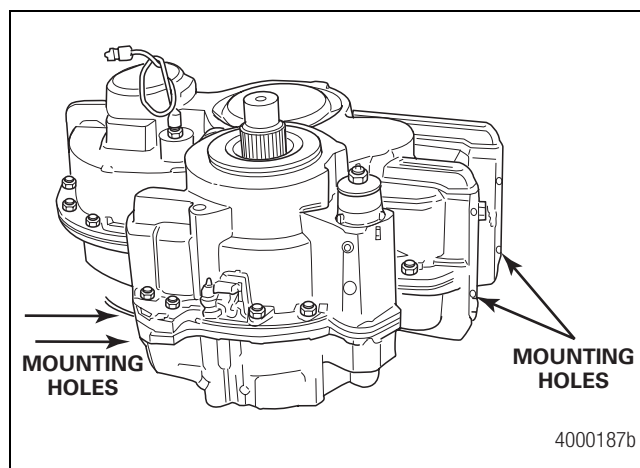

Figure 3.2

NOTE: Eye-bolts permit easier lifting of the transfer case.

13. Install eye-bolts in the lifting holes located in either half of the transfer case housing. Lifting holes are located at the top and bottom of each half of the transfer case near the center. Figure 3.3.

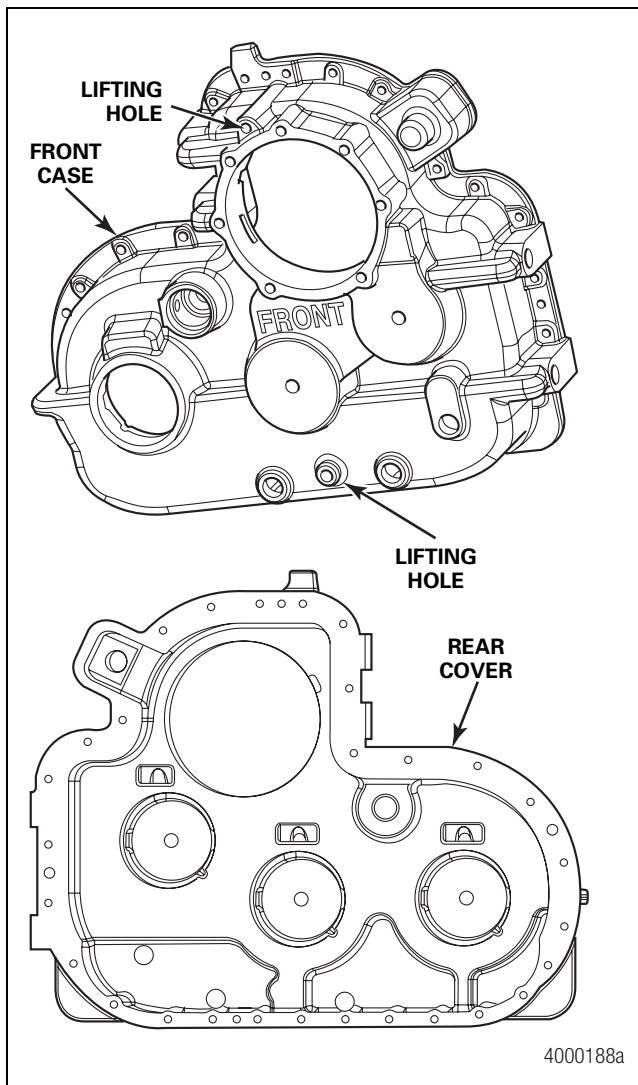

Figure 3.3

⚠ WARNING

Support the transfer case with a lifting strap before mounting the transfer case into the repair stand. A transfer case that is not supported correctly can fall. Serious personal injury and damage to components can result.

NOTE: The transfer case weighs approximately 670 lbs (304.2 kg) without the PTO.

14. Attach a suitable lifting device to the eye-bolts to lift the transfer case. Use the angle iron brackets to mount the case in the repair stand. Figure 3.2.

4 Disassembly

Hazard Alert Messages

Read and observe all Warning and Caution hazard alert messages in this publication. They provide information that can help prevent serious personal injury, damage to components, or both.

⚠ WARNING

To prevent serious eye injury, always wear safe eye protection when you perform vehicle maintenance or service.

Disassemble the Transfer Case

Front and Rear Output Yokes

1. Rotate the transfer case in the repair stand so that the yoke being removed faces UPWARD.
2. Remove the yoke locknuts and washers from the front and rear output shafts.
3. Use a yoke puller to remove the yokes from the output shafts. Do not remove the deflector from the yoke or flange unless it is damaged.
4. Loosen but do not remove the front input yoke, locknut and washer from the front input shaft, input bearing cage and pump assembly. The yoke is used to lift the assembly from the transfer case.
5. **MTC-4208 and -4210 transfer cases only:** Remove the rear input shaft cover capscrews and rear cover, or PTO, if equipped, from the rear transfer case cover. Refer to the procedure in this section.
6. **MTC-4208 and -4210 transfer cases only:** Use a modified 3/4-inch drive three-inch socket to remove the large input-shaft retaining nut located on the opposite end of the yoke. Refer to Section 13.
 - If you are not able to remove the input-shaft retaining nut, you will not be able to remove the front input shaft before you open the housing. Skip Step 1 through Step 4 in the following procedure.

Front Input Shaft, Input Bearing Cage and Pump Assembly

1. Remove the inlet oil tube from the transfer case by loosening the fittings at the lower front case and input-bearing cage. Figure 4.1.

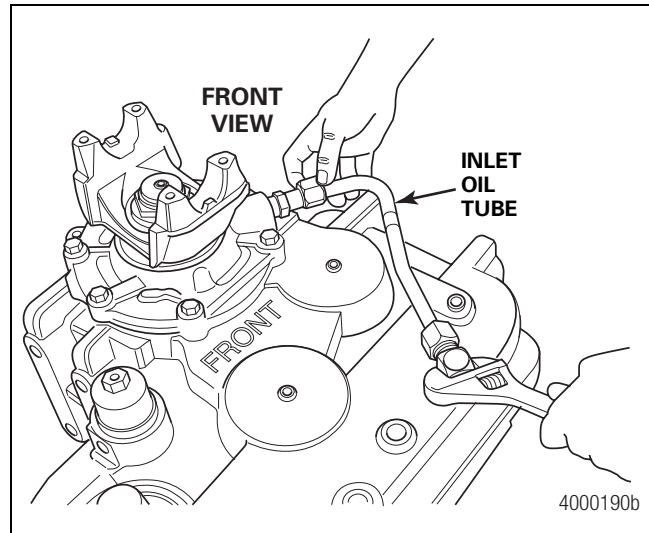

Figure 4.1

2. Remove the capscrews securing the input bearing cage and pump assembly.

NOTE: The high- and low-range clutch collar becomes loose on the shift fork as the input bearing cage and pump assembly is removed and may drop into the case. Shifting the transfer case into high range keeps the shift collar on the high-range gear, which keeps it in place. Also, shifting into high range allows easier rear cover removal on the MTC-4208 and -4210 transfer cases.

3. Shift the transfer case into high range using compressed air at the high-range port of the shift cylinder. Figure 4.2 and Figure 2.2.

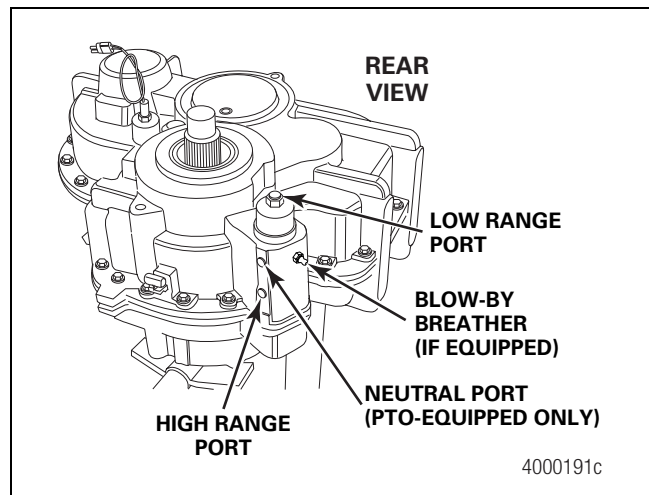

Figure 4.2

4. With the front input yoke still installed, remove the yoke, input shaft, input bearing cage and pump as an assembly. Figure 4.3.

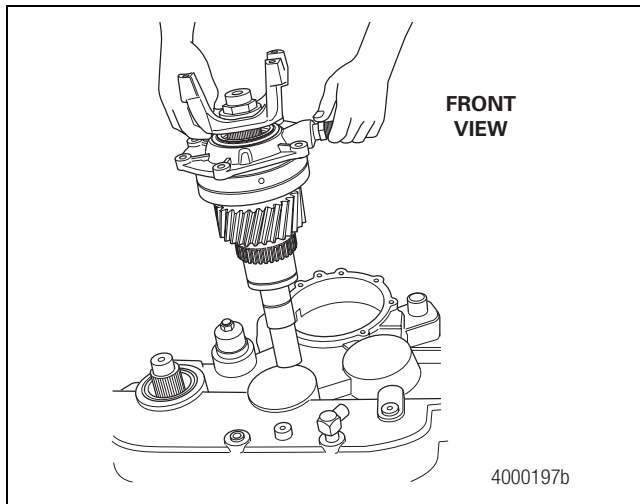

Figure 4.3

5. Use the following procedure to disassemble the high/low shift components before you separate the case halves.
 - A. Disconnect the air lines used to shift in the previous steps. Figure 4.4.
 - B. Remove the high and low range shift cylinder from the rear cover of the transfer case.
 - C. Remove the outer shift piston snap ring from the shift shaft. Remove the shift piston. Figure 4.5.
 - D. Remove the inner shift piston snap ring from the shift shaft. Remove the shift piston. Figure 4.6.

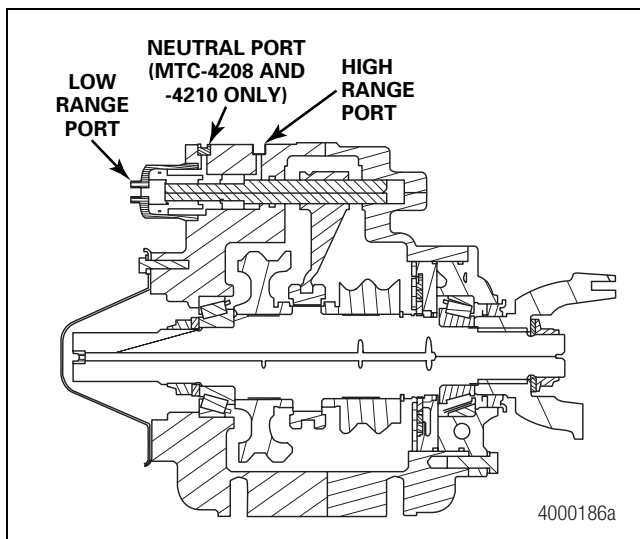

Figure 4.4

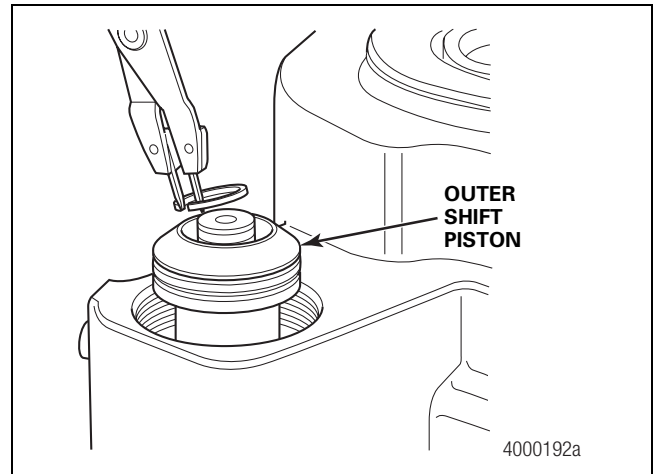

Figure 4.5

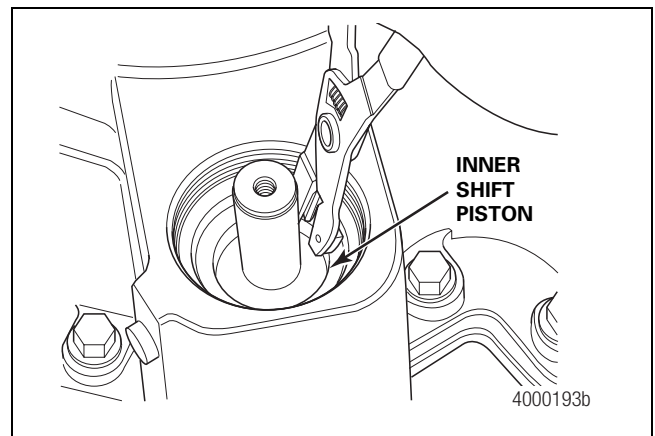

Figure 4.6

6. Use the following procedure to separate the case halves.
 - A. Remove the capscrews securing the rear cover to the front case.
 - B. Use a pry bar to separate the two halves of the transfer case at the pry tab locations around the case.
 - C. Place eye-bolts into the rear cover lift holes located at the top and bottom of the cover.
 - D. Attach a suitable lifting device to the eye-bolts. Lift the rear cover from the front case.
 - E. As the rear cover is lifted, verify that the high and low shift shaft remains in the case by placing pressure on the shaft while separating the transfer case halves.
 - F. The rear output shaft and high-range gear are removed as an assembly along with the rear cover on MTC-4213 transfer cases only. The shaft is pressed into the bearing assembly which keeps the shaft retained in the housing.

4 Disassembly

7. **MTC-4208 and -4210 transfer cases only:** Remove the high range helical gear.
8. Remove the high and low shift fork, shift shaft and clutch collar from the front case. Figure 4.7.

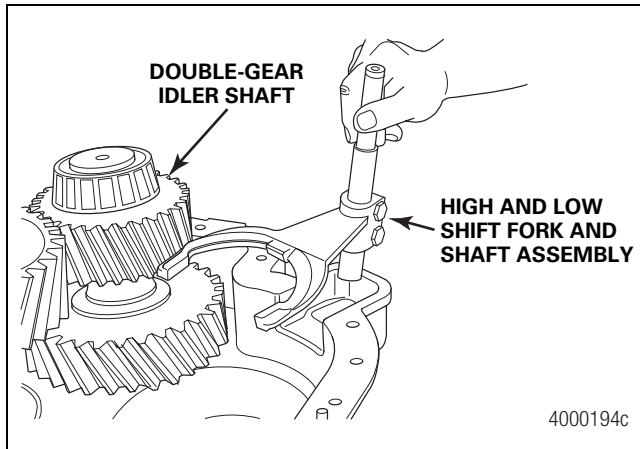

Figure 4.7

9. Remove the single-gear idler shaft, or rear output on MTC-4208 and -4210 transfer cases, and the double-gear idler shaft from the case. Remove the front output shaft, clutch collar, shift fork and spring as an assembly. Figure 4.8.

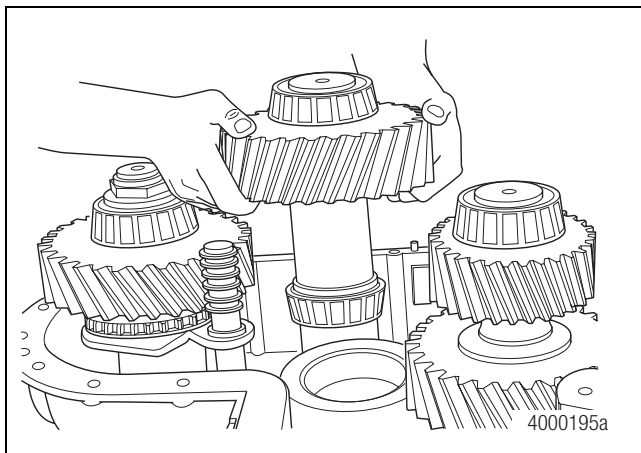

Figure 4.8

10. Remove the shift cylinder and push rod from the front case. Remove the two locating dowel pins. Note their correct location.

⚠ WARNING

Observe all warnings and cautions provided by the press manufacturer to avoid damage to components and serious personal injury.

Use a chain and suitable lifting device to secure the rear cover in the press to prevent serious personal injury and damage to components.

11. Set the rear cover with the rear output shaft as an assembly into a suitable press. Figure 4.9.

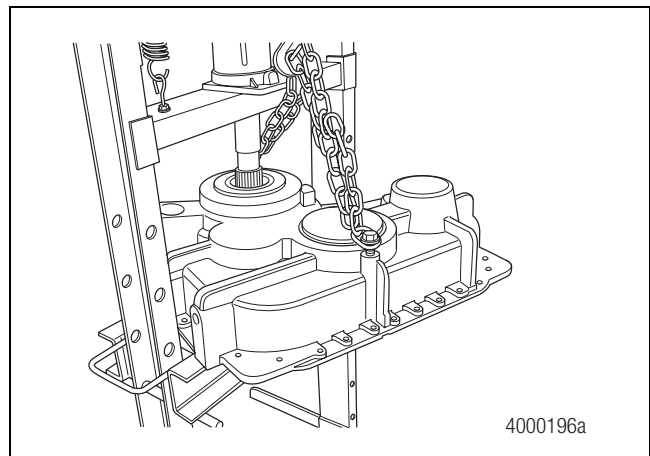

Figure 4.9

⚠ WARNING

The rear output shaft assembly is heavy. Support the assembly to prevent it from dropping during the pressing operation. Serious personal injury and damage to components can result.

12. Press the rear output shaft assembly out of the rear cover. Figure 4.9.
13. Use a suitable puller to remove the rear output shaft outer bearing cone and cup from the rear cover. Discard the cone and cup.
14. Inspect the rear output shaft inner bearing cone and cup for wear or damage. Replace a worn or damaged bearing cone and cup.

Front Input Shaft, Input Shaft Bearing Cage and Oil Pump

1. Support the front input shaft and bearing cage assembly at the workbench. Figure 4.10.

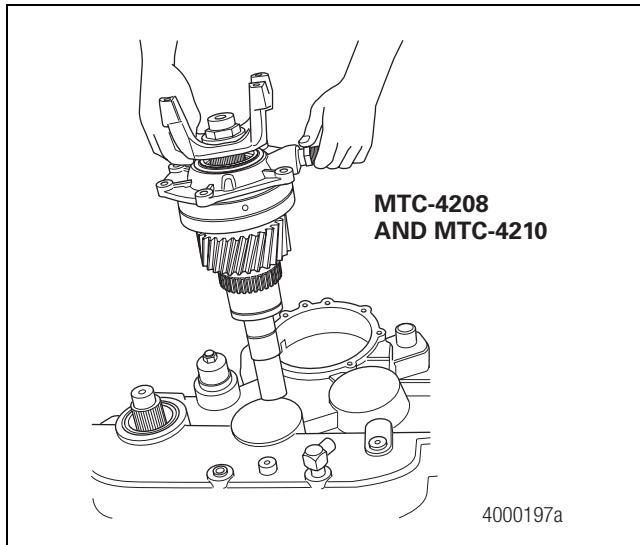

Figure 4.10

2. Use a yoke puller to remove the front input yoke. Figure 4.11.

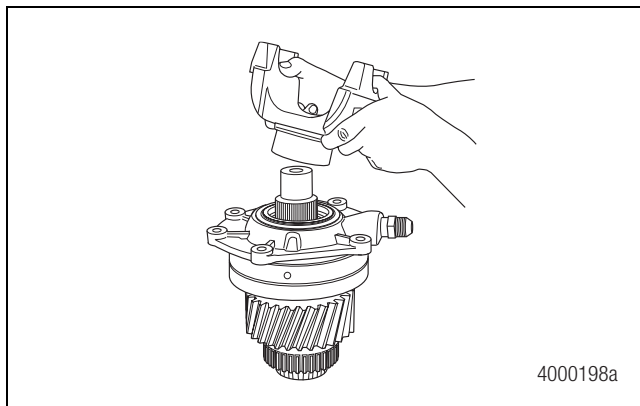

Figure 4.11

3. Lift the front input bearing cage and oil pump assembly off the input shaft. Figure 4.12.

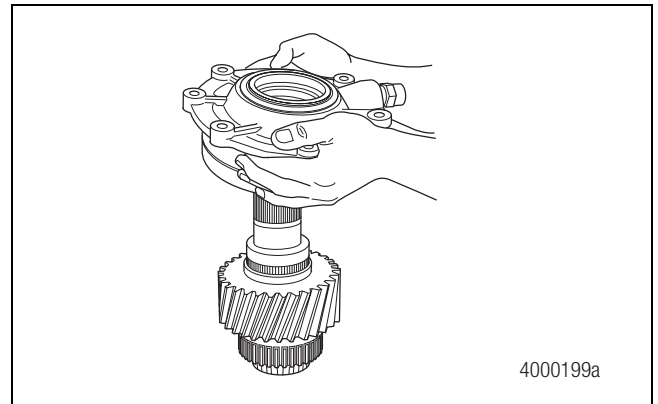

Figure 4.12

4. Remove the spiral snap ring that retains the small helical gear on the input shaft. Lift the small helical gear off the shaft. Figure 4.13.

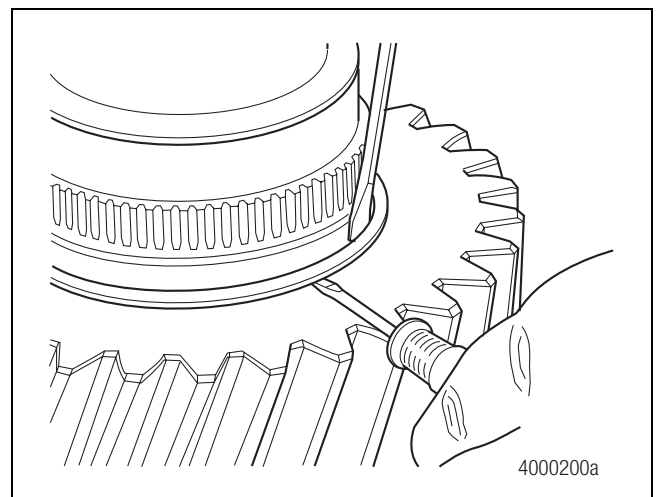

Figure 4.13

5. Remove the pump from the input-bearing cage to service the front input shaft tapered roller bearing cone and cup.
6. Remove the six bolts retaining the oil pump to the input-bearing cage.
7. Mark the position of the pump to the cage for reassembly. Figure 4.14.

4 Disassembly

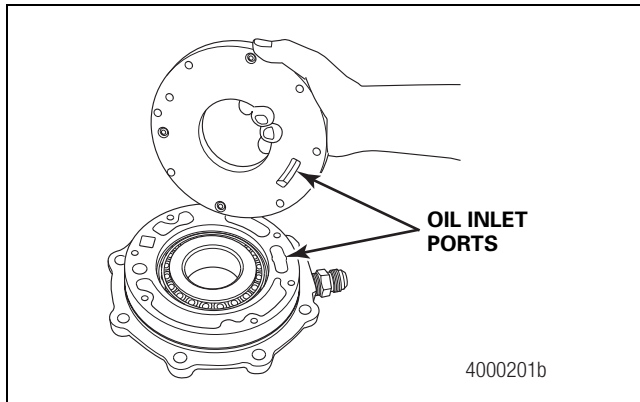

Figure 4.14

8. Match the pump oil inlet to the cage oil inlet. Match the chamfered relief port in the oil pump with the relief valve and spring assembly in the cage.
9. Replace the bearing cone and cup as necessary.
10. Inspect the pump inner rotor in the spline area for cracks or other damage. The entire pump must be replaced if the pump or inner gear rotor is damaged in any way.

Idler Gear Shaft

1. Use a suitable bearing cone puller to remove the bearing cones as necessary from the single idler-gear shaft, rear output shaft on MTC-4208 and -4210 transfer cases, or double idler-gear shaft assemblies.
2. Inspect and replace bearing cones with new as needed. Replace bearing cones and cups as a set.
3. Inspect the shafts and gears for wear or damage.

Optional PTO Assembly on MTC-4208 and -4210 Transfer Cases

1. Rotate the transfer case in the repair stand so that the PTO assembly, if so equipped, is facing UPWARD. Figure 4.15.
2. Remove the yoke nut, washer and yoke. Use a yoke puller to remove the yoke.
3. Remove the PTO indicator switch from the shift plate, if equipped.
4. Remove the cage mounting capscrews and washers from the PTO. Lift the PTO assembly off the transfer case.

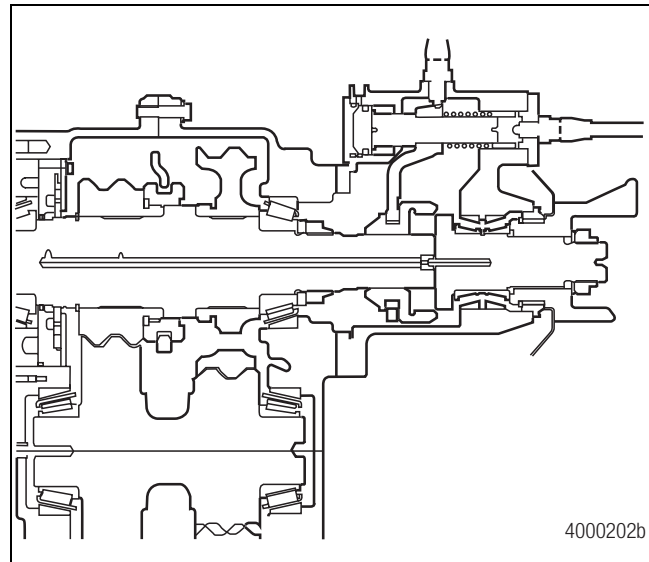

Figure 4.15

⚠ WARNING

Take care when you remove the spring-loaded PTO cap. Serious personal injury and damage to components can result.

5. Carefully remove the spring-loaded PTO cap by turning each bolt a few turns at a time until all the bolts can be removed at once.
6. Remove the capscrews from the cover of the declutch piston. Remove the cover.
7. Remove the PTO piston push rod and the return spring. Remove the O-ring seal from the PTO piston.
8. Remove the O-ring seal on the cover. Discard the seal. Remove the shift fork and clutch collar.
9. Remove the oil and dirt seals from the bearing cage assembly. Discard the seals.
10. Press the shaft out of the bearing cage. Remove the bearing assembly.
11. Remove the bearing cups as a unit with the bearing spacer by pressing the cups out of the bearing cage. Do not separate these parts. They are a matched set.

Hazard Alert Messages

Read and observe all Warning and Caution hazard alert messages in this publication. They provide information that can help prevent serious personal injury, damage to components, or both.

WARNING

To prevent serious eye injury, always wear safe eye protection when you perform vehicle maintenance or service.

Clean, Dry and Inspect Parts

Ground and Polished Parts

WARNING

Solvent cleaners can be flammable, poisonous and cause burns. Examples of solvent cleaners are carbon tetrachloride, and emulsion-type and petroleum-base cleaners. Read the manufacturer's instructions before using a solvent cleaner, then carefully follow the instructions. Also follow the procedures below.

- Wear safe eye protection.
- Wear clothing that protects your skin.
- Work in a well-ventilated area.
- Do not use gasoline, or solvents that contain gasoline. Gasoline can explode.
- You must use hot solution tanks or alkaline solutions correctly. Read the manufacturer's instructions before using hot solution tanks and alkaline solutions. Then carefully follow the instructions.

CAUTION

Do not use hot solution tanks or water and alkaline solutions to clean ground or polished parts. Damage to parts can result.

If required, use a sharp knife to remove gasket material from parts. Be careful not to damage the ground or polished surfaces.

1. Use a cleaning solvent, kerosene or diesel fuel, to clean ground or polished parts or surfaces. NEVER USE GASOLINE.
2. Remove gasket material from the parts. Take care not to damage the ground surfaces.
3. DO NOT clean ground or polished parts in a hot solution tank, water, steam or alkaline solution.

Parts with a Rough Finish

1. Use a cleaning solvent or a hot solution tank with a weak alkaline solution to clean parts with a rough finish.
2. Leave the parts in the hot solution tank until they are completely cleaned and heated. When the parts are clean, remove them from the tank.
3. Wash the parts with water until you completely remove the alkaline solution.
4. Clean the three magnets attached to the bottom of the front case.
5. Remove and clean the magnetic drain plug.

Transfer Case Assemblies

CAUTION

Close or cover all openings before steam cleaning. Steam can cause component damage.

1. Steam clean transfer cases on the outside to remove heavy amounts of dirt.
2. Before steam cleaning the transfer case, close or put a cover over all openings in the case.
3. Remove any remaining silicone sealant from the transfer case halves using a suitable scraper or wire wheel.

Dry Cleaned Parts

CAUTION

Dry bearings with clean paper or rags. Do not use compressed air, which can cause abrasive particles to contaminate the bearings. Damage to the components and reduced lining life can result.

Immediately after cleaning, use clean paper, rags or compressed air to dry the parts.

Prevent Corrosion

NOTE: Parts must be clean and dry before you lubricate them.

1. If you assemble the parts immediately after you clean them, lubricate the clean, dry parts with grease to prevent corrosion.
2. If you store the parts after you clean them, apply a corrosion-preventive material to all machined surfaces. Store the parts in a special paper or other material that prevents corrosion.

5 Prepare Parts for Assembly

Oil Seals and O-Rings

Discard all oil seals and O-rings. Replace with new parts.

Inspect Parts

It is very important to inspect all parts carefully and completely before the transfer case is assembled. Check all parts for wear and stress. Replace all damaged parts.

1. Inspect the tapered roller bearings. Inspect the cup, cone, rollers and cage of all tapered roller bearings in the assembly. If any of the following conditions exist, the bearing must be replaced:
 - The center of the large diameter end of the rollers is worn level with or below the outer surface.
 - The radius at the large diameter end of the rollers is worn to a sharp edge. Figure 5.1.
 - A visible roller groove is worn in the inner race surfaces of the cup or cone. The groove can be seen at the small or large diameter end of both parts.
 - Deep cracks or breaks appear in the surfaces of the cup, cone inner race or rollers. Figure 5.2.
 - Bright wear marks appear on the outer surface of the roller cage. Figure 5.3.
 - The rollers and surfaces of the cup and cone inner race that touch the rollers are damaged. Figure 5.4.
 - The cup and cone inner race surfaces that touch the roller are damaged. Figure 5.5.

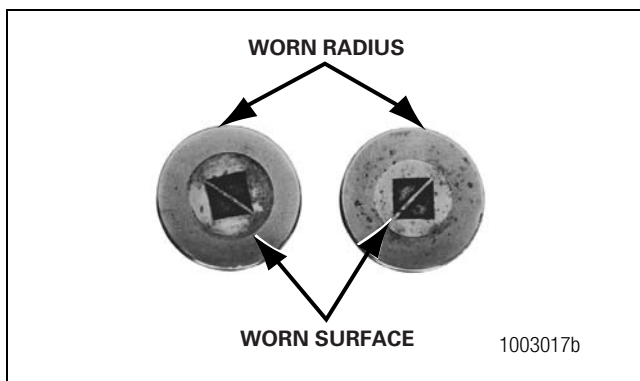

Figure 5.1

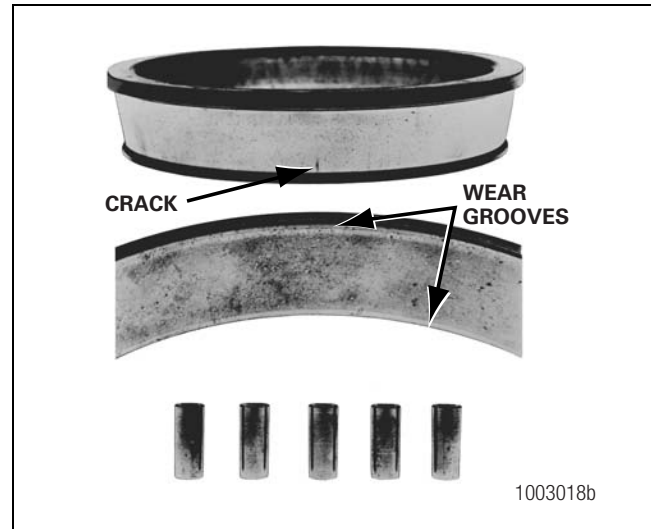

Figure 5.2

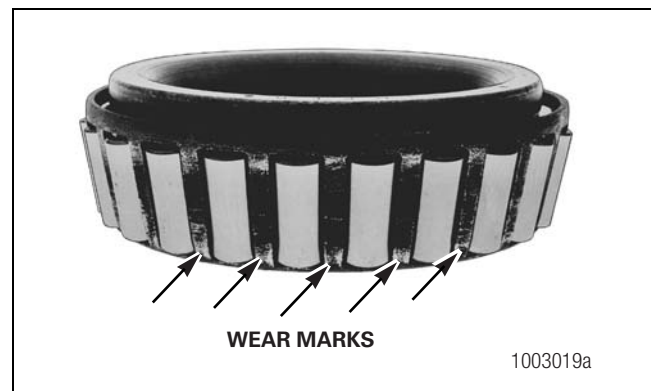

Figure 5.3

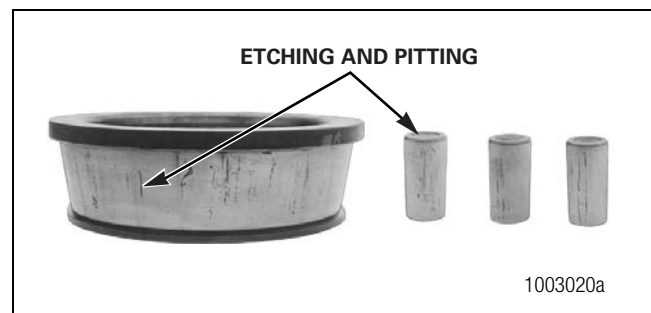

Figure 5.4

5 Prepare Parts for Assembly

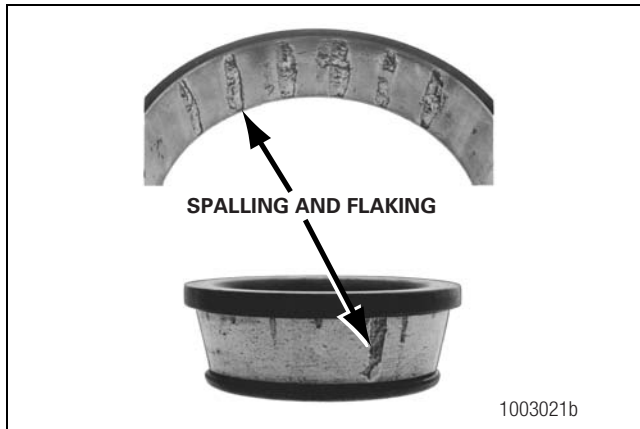

Figure 5.5

2. Inspect the gears for wear or damage. Replace worn or damaged gears.
3. Inspect the housing.
 - A. Remove all dirt from the housing and oil lubrication passages, troughs, slots and holes.
 - B. Inspect machined surfaces for cracks and damage. Repair or replace damaged parts.
4. Inspect all shafts, flanges and yokes for wear, stress and cracks at the splines, shaft and yoke ears. Replace shafts, flanges and yokes that are worn or cracked.
5. Verify that any oil passages in the shafts are clean and free of debris.
6. Inspect the declutch and output shaft components, if applicable.
 - A. Inspect the clutch collar internal splines, external declutch teeth and shift for grooves. Replace worn, cracked or damaged collars.
 - B. Inspect the collar pads of the shift fork for wear. If the pads are worn, replace the shift fork.
 - C. Inspect the declutch shaft and yoke for wear, stress and cracks at the splines, shaft and yoke ears. Replace worn or cracked shafts and yokes.
 - D. Inspect the declutch or PTO push rod and piston for wear or damage. Replace worn or damaged parts.
7. Inspect the splines on the pump inner rotor for cracks along the spline area. Also, check for excessive wear. Replace the pump if these conditions exist.
8. Remove and inspect the restrictor plug at the end of the input shaft.

9. Verify that the orifice is clear of debris.

Helical Gears

Inspect the helical gear teeth, splines and journals. If any of the following conditions exist, replace the gear.

- A crack in the root of a tooth or along the tooth flank. Figure 5.6.
- Severe scoring or fretting on the surface of a tooth. Gears with scoring and fretting on the teeth, but without cracks, may continue to operate satisfactorily with higher noise. Figure 5.7.
- Cracks along the internal journal of the input gears. Figure 5.8.
- Deep gouges or metal transfer along the input gear journals. Figure 5.9.
- Chipped or severely worn shifting splines on the input gears.
- Chipped or cracked splines on the output gears.

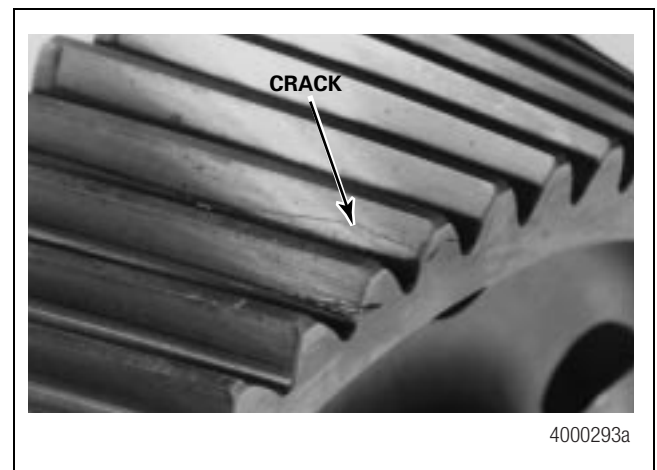

Figure 5.6

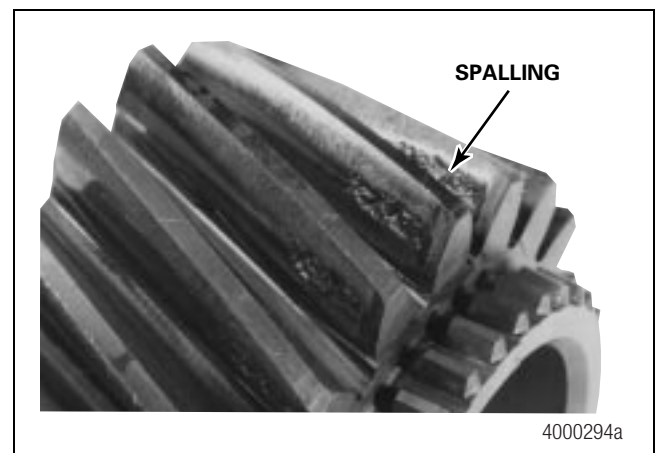

Figure 5.7

5 Prepare Parts for Assembly

Shafts

Inspect the input and output shafts for damage to the gear journals, shifting splines, threads and gear retaining splines. If any of the following conditions exist, replace the shaft.

- Deep gouges or metal transfer along the input shaft journals. Figure 5.10.
- Chipped or worn shifting splines on the input shaft.
- Chipped or cracked splines on the output shaft. Figure 5.11.
- Cracks along the yoke splines, bearing journal abutments or cross-drilled holes. Magnaflux may be necessary to see small cracks.

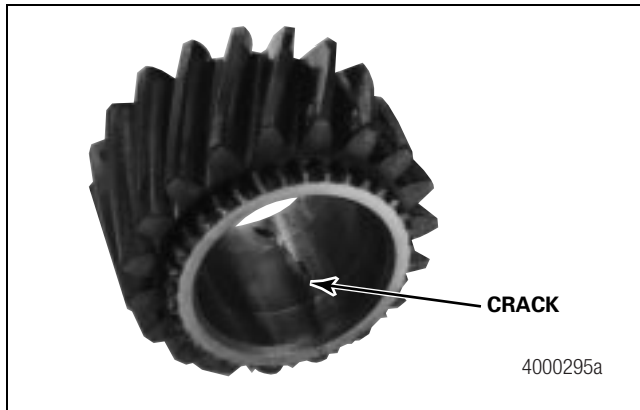

Figure 5.8

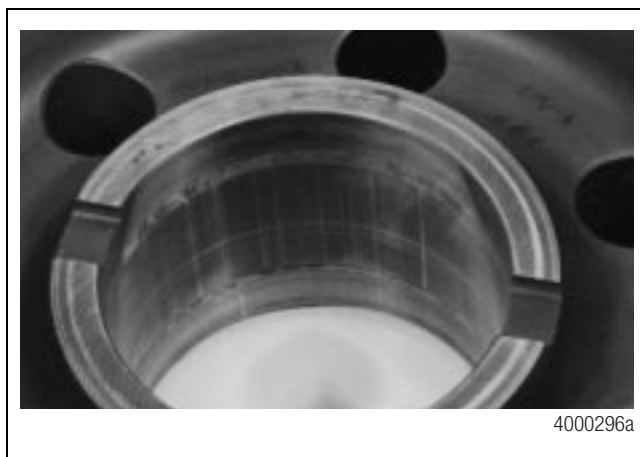

Figure 5.9

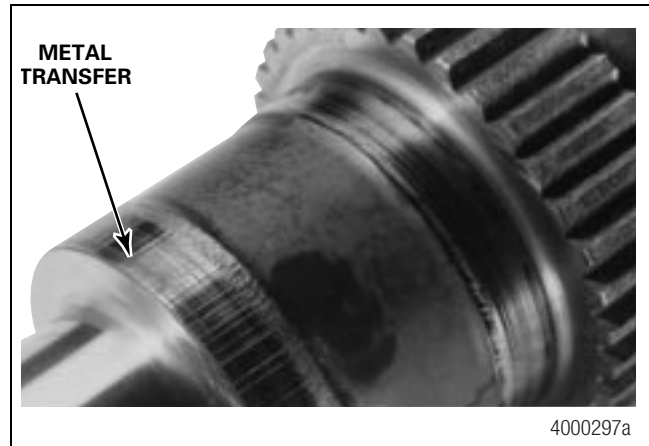

Figure 5.10

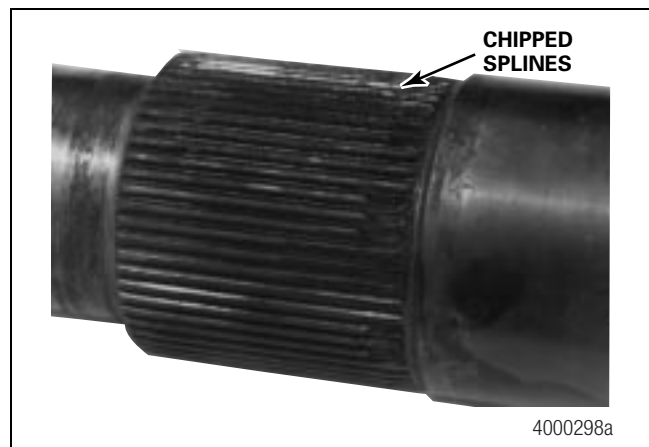

Figure 5.11

PTO Components

Inspect the PTO housing, shaft, taper bearings, shift collar, shift fork and sensors for damage. If any of the following conditions exist, replace the component.

- Cracks in the housing.
- Cracks along the shaft yoke spline or ball bearing abutment. Magnaflux may be necessary to see small cracks.
- Chipped or cracked shifting splines on the shift collar or shaft.
- The rollers of the taper bearings do not roll easily or lack lubrication. The raceway is cracked or dented.
- Cracked or missing tangs on the shift fork arms.
- The sensor ball sticks or does not return to its resting position. The sensors do not complete a circuit when tested with a volt-ohm meter (VOM).

High and Low Shifting Components

Inspect the shift collar, shift fork, shift shaft, retaining pins, shift cylinder, piston, O-ring and case halves for damage. If any of the following conditions exist, replace or repair the component.

- Cracked or missing tangs on the shift fork arms.
- Chipped or cracked shifting splines on the shift collar.
- Cracks or deep gouges on the shift shaft.
- The retaining pins in the shift shaft are not 0.100-inch (2.54 mm) above the shaft diameter. Remove and set to the correct position.
- Gouges on the inside of the shift cylinder.
- Torn or feathered areas on the O-ring.
- Deep gouges in the shifting bores of the case halves.

Oil and Lubrication System

The lubrication system is extremely important to the performance of the transfer case. Inspect all parts closely for excessive wear or damage. Perform the following checks.

1. Inspect the oil for metal shavings, dirt and consistency. Perform an analysis if the oil appears contaminated.
2. Check the magnets for metal shavings. A small amount of metal shavings is normal. However, excessive build-up indicates gear and bearing damage. Thoroughly remove all metal shavings from the magnets. The magnets must be firmly fastened to the case.
3. Check the sump screen. Remove any material that may restrict oil flow through the mesh.
4. Inspect the seals closely. Look for nicks and tears on all sealing lips. Any damage is likely to result in a seal leak.
5. Check the pump for easy rotation. If the internal gear does not spin easily or jams when rotating the crescent plate, replace the pump.
6. Check the oil line for damage. Replace if it is dented or kinked.
7. Verify that the pump drive pins are 0.063-inch (1.6 mm) above the diameter of the shaft. Remove and set to the correct position if necessary.

Transfer Case Halves

Inspect the case halves for cracks and internal wear. If any of the following conditions exist, replace the damaged parts.

- A crack in either case half.
- Deep gouges in the shifting bores.

Preparing the Case and Cover and Seal Replacement

1. Pry out all oil seals using a suitable pry bar.
2. As necessary, use a suitable puller to remove the bearing cups pressed into the transfer case halves.
3. Clean and inspect the transfer case and cover for cracks, worn threaded holes or other wear or damage. Clean the gasket surfaces of both transfer case halves using a suitable gasket scraper or wire wheel.
4. Press new bearing cups into the case halves as necessary. Refer to Section 6 for bearing setting procedures.
5. Inspect the bearing end play to ensure that it's within specification. Adjust the end play, if required. Refer to Section 6.
6. Install new oil seals into the case halves. Use Meritor seal driver, part number R4422402, for a 3.25-inch nominal diameter seal. The seal driver is included in Meritor Kit 4454. Refer to the Service Notes page on the front inside cover of this manual to obtain this Kit.

6 Assembly

Hazard Alert Messages

Read and observe all Warning and Caution hazard alert messages in this publication. They provide information that can help prevent serious personal injury, damage to components, or both.

⚠ WARNING

To prevent serious eye injury, always wear safe eye protection when you perform vehicle maintenance or service.

When you apply some silicone gasket materials, a small amount of acid vapor is present. To prevent serious personal injury, ensure that the work area is well-ventilated. Read the manufacturer's instructions before using a silicone gasket material, then carefully follow the instructions. If a silicone gasket material gets into your eyes, follow the manufacturer's emergency procedures. Have your eyes checked by a physician as soon as possible.

Take care when you use Loctite® adhesive to avoid serious personal injury. Read the manufacturer's instructions before using this product. Follow the instructions carefully to prevent irritation to the eyes and skin. If Loctite® adhesive material gets into your eyes, follow the manufacturer's emergency procedures. Have your eyes checked by a physician as soon as possible.

Assemble the Transfer Case

1. Lubricate all bearing cups and cones, gears and shaft assemblies before installation into the case. Use synthetic SAE 50 oil, Meritor specification O-81.
2. With the inside of the front case facing UPWARD, install the single-gear, or rear output shaft on MTC-4208 and -4210 transfer cases, and double-gear idler shaft assemblies. Figure 6.1.

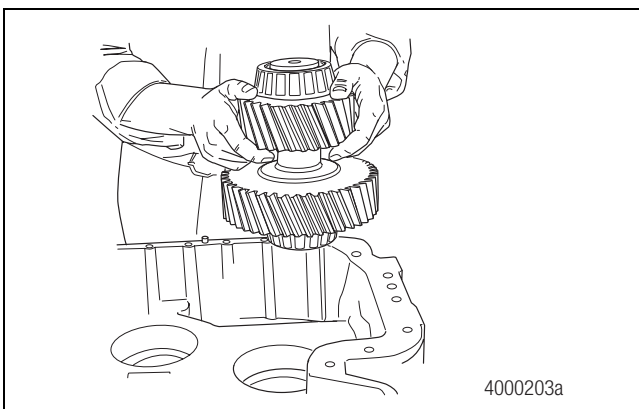

Figure 6.1

3. Position the clutch collar onto the stamped shift fork. Position the shift fork and clutch collar onto the front output shaft clutch hub.
4. Install the front output shaft, shift fork and clutch collar over the front output shaft tapered roller bearing in the front case. Figure 6.2.

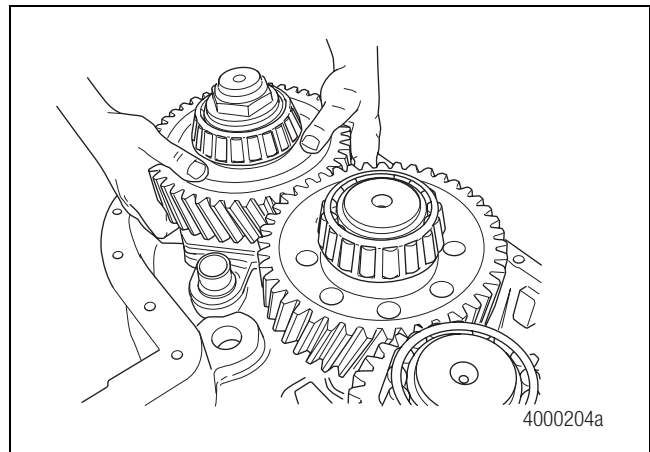

Figure 6.2

5. While holding the shift fork and clutch collar in place, insert the push rod through the case and through the stamped shift fork. Figure 6.3.

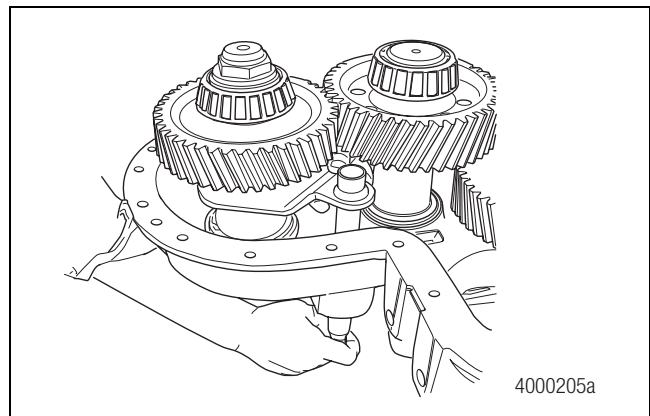

Figure 6.3

6. Temporarily install the shift cylinder onto the case to secure the push rod in place.
7. The shift cylinder requires Loctite® sealant for final assembly.
8. Install the release spring over the push rod and shift fork.

- Install the high and low shift fork and shift shaft into position in the front case. Figure 6.4.

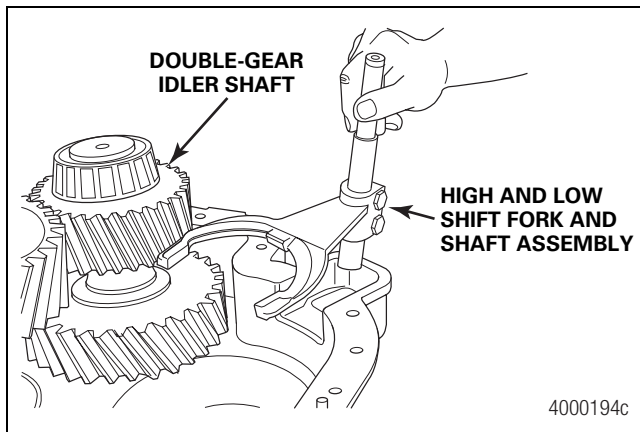

Figure 6.4

- Determine all shaft bearing end plays before final assembly. Refer to the procedures in this section.
- Install the two locating dowel pins into the corresponding holes in the front case.
- Use a suitable lifting device to install the rear cover and output shaft as an assembly over the front case. Figure 6.5. Guide the cover over the shift fork and push rod as the cover is being set into place over the case.

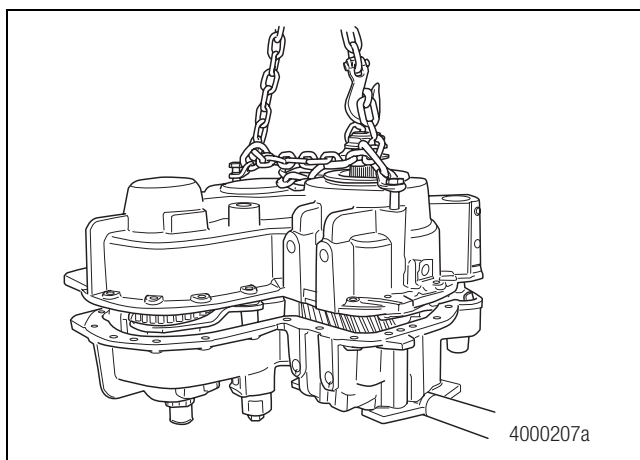

Figure 6.5

- Verify that the locating dowel pins have engaged both the case and the cover and that the cover is fully seated on the case.
- Secure the case to the cover joint by assembling at least six equally spaced case-to-cover capscrews.

- Assemble all remaining case-to-cover capscrews upon achieving the correct end play measurement on all shafts.
- Lubricate and install the O-ring into the rear cover push rod journal. Use a light coat of lithium-based grease, Meritor specification O-688, prior to cover installation. Figure 6.6.

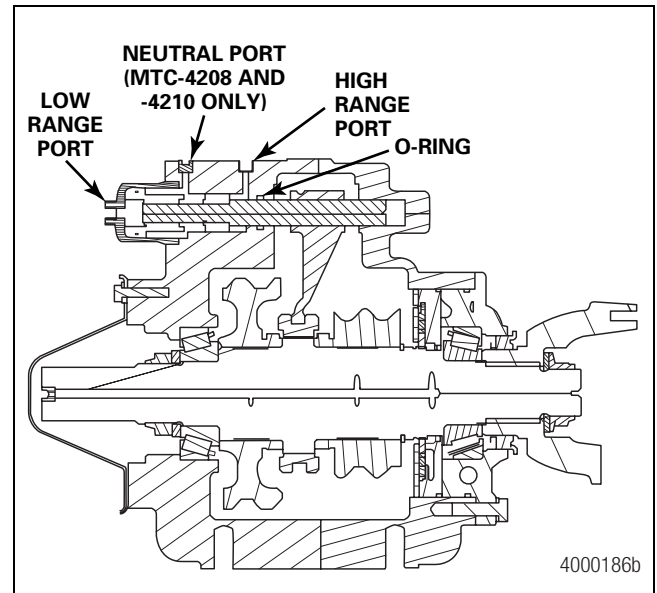



Figure 6.6

- Apply Loctite® 518 sealant to the case-to-cover flange. Apply a 1/8-inch (3 mm) bead of sealant around the entire flange between each bolt hole making sure to encircle each hole.
- Reinstall the rear cover over the front case. Guide the high and low shift shaft and push rod through the cover as necessary. Verify that the cover is aligned with the locating dowel pins and correctly seated.
- If the capscrews are not pre-covered, apply Loctite® 272 sealant to the first three threads of the cover-to-case capscrews.
- Install all cover-to-case capscrews and flat washers. Tighten the capscrews to 60-75 lb-ft (81-102 N•m). 

6 Assembly

Adjustment

MTC-4213 Rear Output Shaft End Play

NOTE: Determine the rear output shaft bearing end play before installing the rear cover onto the front case.

1. If the rear output shaft and cover assembly has been disassembled, install the rear output shaft, bearing cones, spacer and shims, rear oil seal and yoke into the rear cover. Temporarily tighten the yoke nut to 200 lb-ft (271 N•m). Place the rear cover on the bench to measure bearing end play. Figure 6.7. 

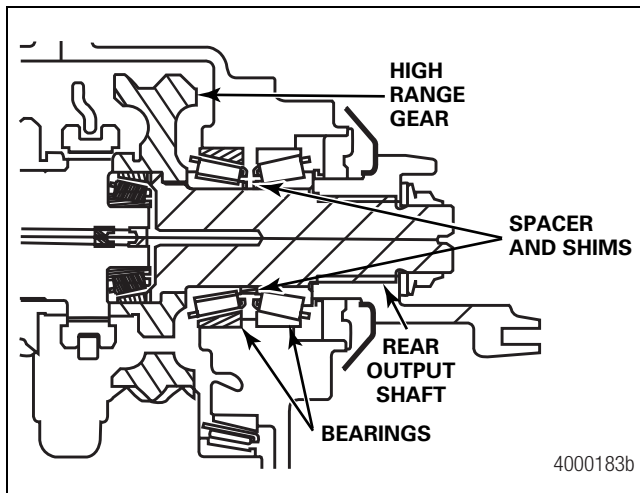

Figure 6.7

2. Rotate the output shaft several times to seat the bearings.
3. Use a suitable dial indicator setup and pry UP on the yoke to determine bearing end play. End play should be 0.002-inch \pm 0.001-inch (0.050 \pm 0.025 mm). To obtain a consistent reading, perform this operation two or three times. Record the reading for this shaft.
 - **If the bearing end play is within specification:** The rear cover assembly is ready for installation.
 - **If the bearing end play is out of specification:** Remove the rear output shaft and install an appropriate spacer and shim combination between the bearing cones.
4. If necessary, remove the rear output shaft. Add shims to increase end play or remove shims to reduce end play. Reinstall the rear output shaft assembly. Recheck the end play.

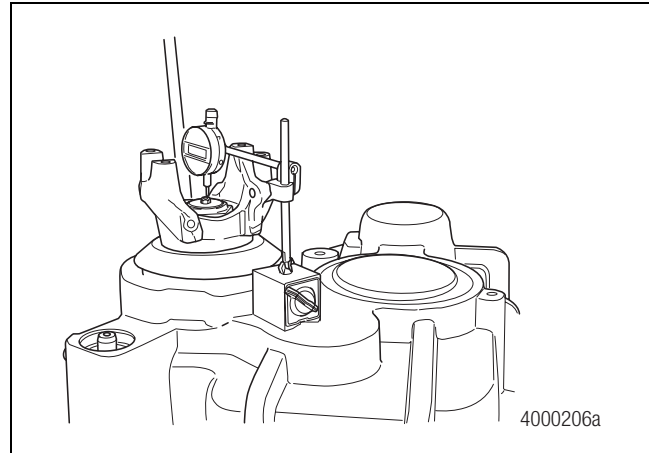

Figure 6.8

MTC-4208 and -4210 Rear Output Shaft End Play

Determine the rear output shaft bearing end play before final assembly. Seals should not be installed until the end plays are set.

1. Before installing the yoke, clean the splines of old silastic. Apply a 1/8-inch (3.175 mm) bead of RTV 732 sealant 360 degrees around the outer two-inches (50.8 mm) of the yoke splines. Figure 6.9.

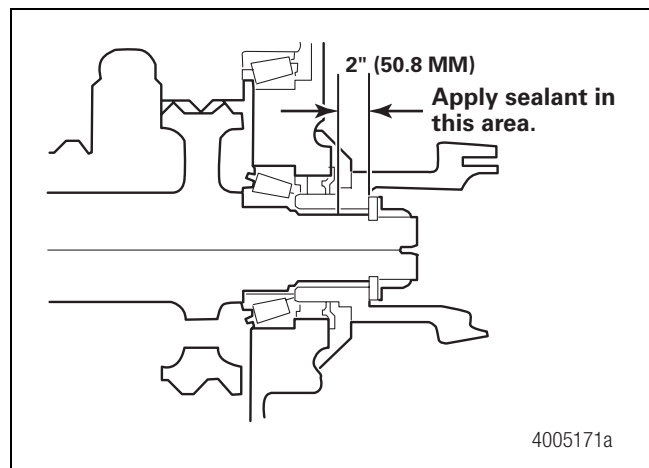



Figure 6.9

2. Install the rear output shaft yoke. Temporarily tighten the yoke nut to 200 lb-ft (271 N•m). 
3. Rotate the output shaft several times to seat the bearings.

- Use a dial indicator to check output shaft bearing end play. Center the dial indicator over the shaft using a ball bearing for accuracy. Figure 6.10.

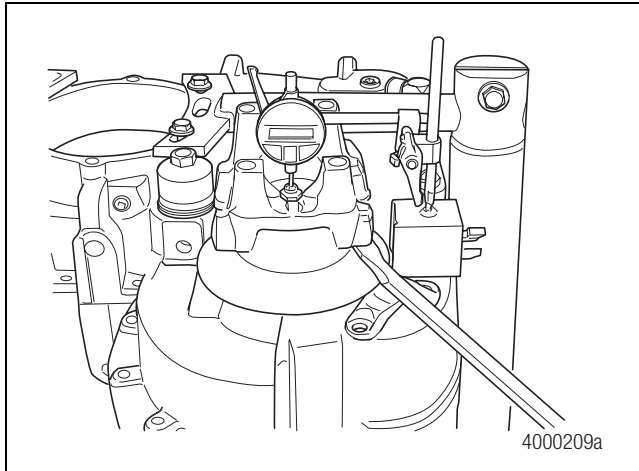

Figure 6.10

- Use a pry bar to lift the yoke to obtain a measurement. To obtain a consistent and averaged reading, perform this operation two or three times. Record the reading for this shaft.
 - If the end play reading is greater than 0.001-0.005-inch (0.025-0.127 mm):** Add shims to reduce end play.
 - If the end play reading is less than specification:** Remove shims to increase end play. Bearing shims come in 0.003-, 0.005- and 0.010-inch (0.08, 0.13 and 0.25 mm) thicknesses.
- If rear output shaft bearing end play requires adjustment, remove the rear output shaft yoke so that the case and cover can be easily separated.
- Measure the end play on the remaining shafts before splitting the case to make adjustments.
- After performing the rear output shaft bearing end play measurement, separate the transfer case halves as necessary to adjust shims and achieve correct the end play on the shaft requiring adjustment.
- Adjust shims to achieve the correct bearing end play on all shafts as required. Refer to the procedure in this section.

Idler Shaft Bearing End Play

Determine the idler shaft bearing end play before final assembly. Seals should not be installed until the end plays are set.

- Temporarily install at least six case-to-cover capscrews evenly spaced around the case.
- Rotate the transfer case so that the front of the case faces UPWARD.
- Remove the 3/8-inch (9.5 mm) pipe plugs at the idler shaft locations on the front of the case.
- To prepare to check idler shaft bearing end play, insert a 1/2"-13 bolt into the shaft through the pipe plug hole, until the bolt is fully seated. The bolt should extend out of the transfer case enough for you to use it to lift the idler shaft.
- Tighten the bolt so that it bottoms in the shaft for an accurate end play measurement.
- Rotate the idler shaft several times to help seat the bearing cones.
- Set up the dial indicator to check the idler shaft bearing end play. Center the dial indicator on the bolt head. Zero the indicator. Figure 6.11.

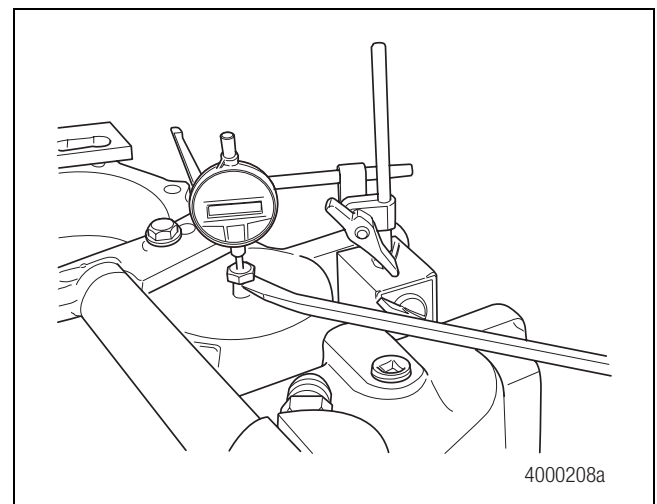



Figure 6.11

6 Assembly

- Use pry bars to lift up on the bolt head to obtain a measurement. To obtain a consistent and averaged reading, perform this operation two or three times. Record the reading for this shaft.
 - If the end play reading is greater than 0.001-0.005-inch (0.025-0.127 mm):** Add shims to reduce end play.
 - If the end play reading is less than specification:** Remove shims to increase end play. Bearing shims come in 0.003-, 0.005- and 0.010-inch (0.08, 0.13 and 0.25 mm) thicknesses.
- Remove the bolt from the shaft. Install the 3/8-inch pipe plug or breather assembly depending on shaft measured. Tighten the bolt to 20-25 lb-ft (27-34 N•m). 
- MTC-4213 transfer case only:** Check the idler shaft bearing end play on the second idler shaft following Step 4 through Step 9. Record the reading for this shaft.
- Check the bearing end play on all other shafts before splitting the case to adjust the bearing end play on the idler shafts.
- Adjust the shims to achieve the correct bearing end play on all shafts as required. Refer to the procedure in this section.

Front Output Shaft End Play

Determine the front output shaft bearing end play before final assembly. Seals should not be installed until the end plays are set.

- Before installing the yoke, clean the splines of old silastic. Apply a 1/8-inch (3.175 mm) bead of RTV 732 sealant 360 degrees around the outer two-inches (50.8 mm) of the yoke splines. Figure 6.12.

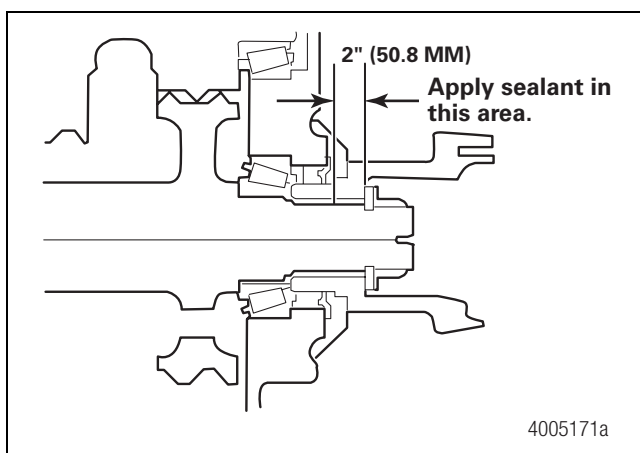



Figure 6.12

- Install the front output shaft yoke. Temporarily tighten the yoke nut to 200 lb-ft (271 N•m). 
- Rotate the output shaft several times to seat the bearings.
- Set up a dial indicator to check the output shaft bearing end play. Center the dial indicator over the shaft using a ball bearing for accuracy. Figure 6.13.

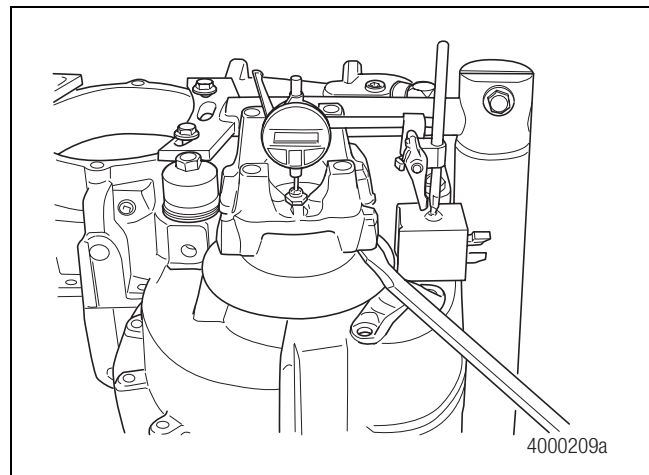

Figure 6.13

- Use a pry bar to lift the yoke to obtain a measurement. To obtain a consistent and averaged reading, perform this operation two or three times. Record the reading for this shaft.
 - If the end play reading is greater than 0.001-0.005-inch (0.025-0.127 mm):** Add shims to reduce end play.
 - If the end play reading is less than specification:** Remove shims to increase end play. Bearing shims come in 0.003-, 0.005- and 0.010-inch (0.08, 0.13 and 0.25 mm) thicknesses.
 - If the front output shaft bearing end play requires adjustment:** Remove the front output shaft yoke so that the case and cover can be easily separated.
- Measure the end play on the remaining shafts before splitting the case to make adjustments.
- After performing the front output shaft bearing end play measurement, separate the transfer case halves as necessary to adjust the shims and achieve the correct end play on the shaft requiring adjustment.
- Adjust the shims to achieve the correct bearing end play on all shafts as required. Refer to the procedure in this section.

Shim Assembly

In order to adjust the end play on any shaft, it is necessary to split the transfer case.

1. Rotate the transfer case in the stand so that the rear cover is facing UP. Remove the case-to-cover capscrews.
2. Use a suitable lift to remove the rear cover. Mount the cover so that the pressed-in bearing cups can be removed.
3. Use a bearing puller to remove the bearing cups from the cover. Shims are placed between the cover and the cup. Refer to the exploded views in this manual.
4. Select the correct shim or shims to achieve the correct end play. If the end play measurement is below 0.001-inch (0.03 mm), which indicates a pre-loaded shaft, start by removing shims until some measurable end play is observed.

Table A: Example of shim selection:

Initial measurement (idler shaft)	0.018-inch (0.46 mm)
Specification	0.001-0.005-inch (0.03-0.13 mm)
Required shim stack	0.017-0.013-inch (0.43-0.33 mm)

Table B: Possible combinations that meet required shim stack:

1 (0.010)	2 (0.005)	1 (0.010)
<u>1 (0.005)</u>	<u>1 (0.003)</u>	<u>2 (0.003)</u>
0.015-inch	0.013-inch	0.016-inch
1 (0.25 mm)	2 (0.13 mm)	1 (0.25 mm)
<u>1 (0.13 mm)</u>	<u>1 (0.08 mm)</u>	<u>2 (0.08 mm)</u>
0.38 mm	0.34 mm	0.41 mm

5. After selecting the correct shim combination, place the shims in the bottom of the bearing bore. Refer to the exploded views in this manual.
6. Press the bearing cup into the bore until it is completely seated. The shims must be centered in the bore while pressing in the bearing cup.
7. Repeat Step 3 through Step 6 for each bearing needing an end play adjustment.

NOTE: Before final assembly, verify that each shim selection procedure results in the correct end play specification. Repeat the end play measurement steps, as necessary, to obtain the correct end play specification on all shafts.

8. Reassemble the cover to the case. Install at least six case-to-cover capscrews.

Assembly

High and Low Shifter

1. Grease all O-ring seals. Use a light coat of lithium-based grease, Meritor specification O-688. Refer to Figure 6.14 for shifter component arrangement.

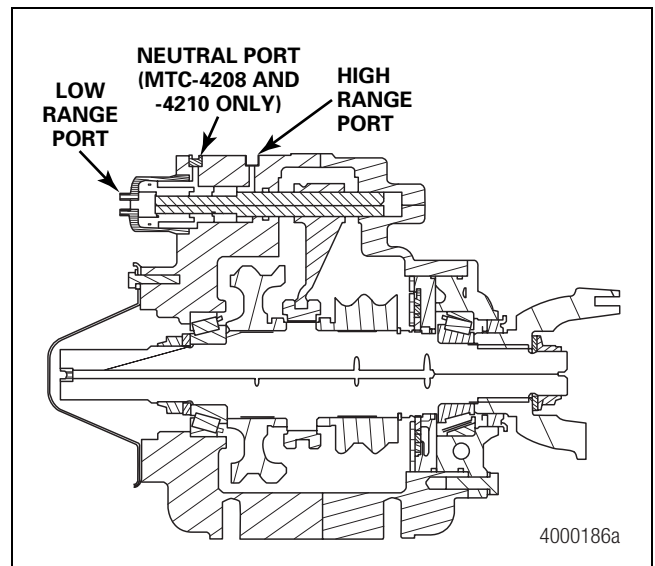

Figure 6.14

2. Install O-rings onto the inside diameter and outside diameter of the inner piston. Install the inner shift piston and snap ring onto the shift shaft. Figure 6.15.

6 Assembly

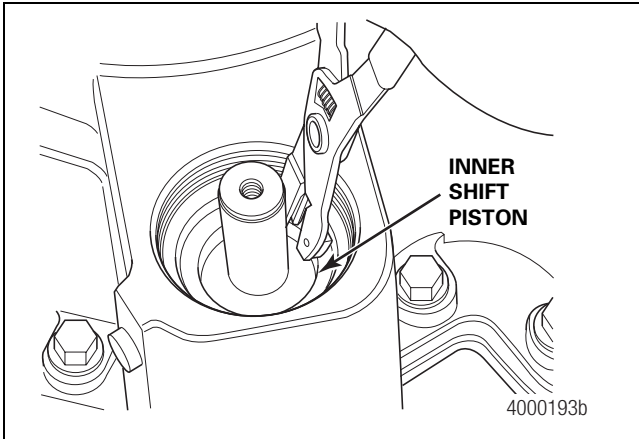

Figure 6.15

3. Install O-rings onto the inside diameter and outside diameter of the outer piston. Install the outer shift piston.
4. Install the outer shift piston outer snap ring onto the shift shaft. Figure 6.16.

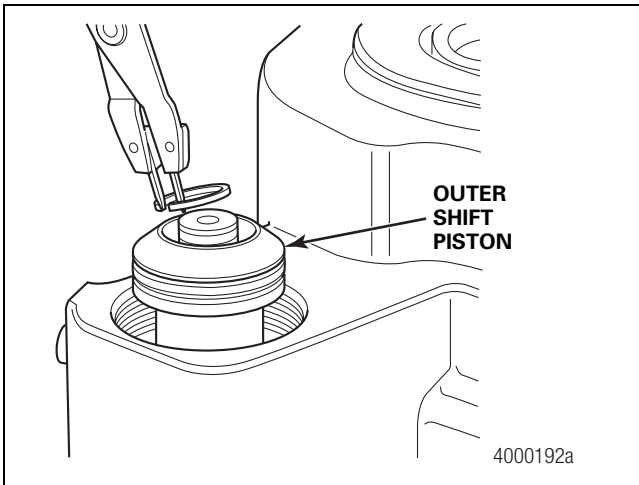





Figure 6.16

5. Apply a 1/8-inch (3 mm) bead of Loctite® 277 sealant to the first three threads of the shift cylinder.
6. Install the high and low shift cylinder. Tighten the cylinder to 85-95 lb-ft (115-129 N•m). 
7. Install the rear output shaft seal using seal driver R4422402, Meritor Kit 4454. Drive the seal until it is fully seated.
8. **MTC-4208 and -4210 transfer cases only:** Install the rear output shaft yoke, washer and yoke nut. Tighten the nut to 700-900 lb-ft (949-1220 N•m). 

Front Axle Shifter

1. Rotate the transfer case to install the front axle shift cylinder.
2. Remove the front axle shift cylinder used to temporarily hold the shift shaft in place.
3. Grease the O-ring on the piston and install the piston into the cylinder.
4. Apply a 1/8-inch (3 mm) bead of Loctite® 277 sealant to the first three threads of the shift cylinder.
5. Install and tighten the shift cylinder to 85-95 lb-ft (115-129 N•m). 
6. Install the front output shaft oil seal using oil seal driver R4422402, Meritor Kit 4454. Drive the seal until it is fully seated. Figure 6.17.

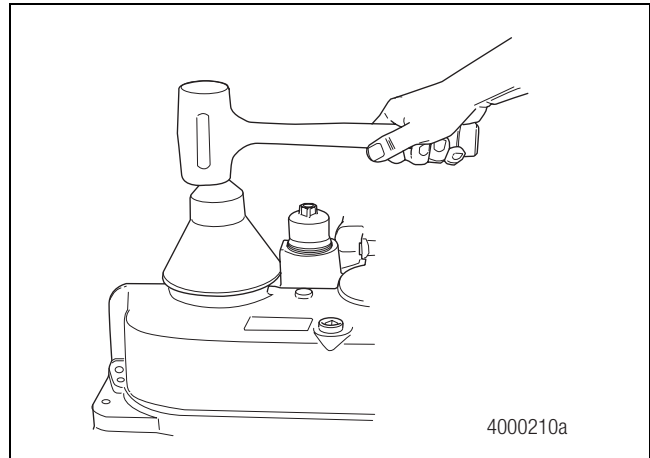



Figure 6.17

7. Install the front output shaft yoke, washer and yoke nut. Tighten the yoke nut to 700-900 lb-ft (949-1220 N•m). 

Front Input Shaft, Input Shaft Bearing Cage and Oil Pump Assembly

1. Place the large O-ring around the groove on the bearing cage. Figure 6.18.

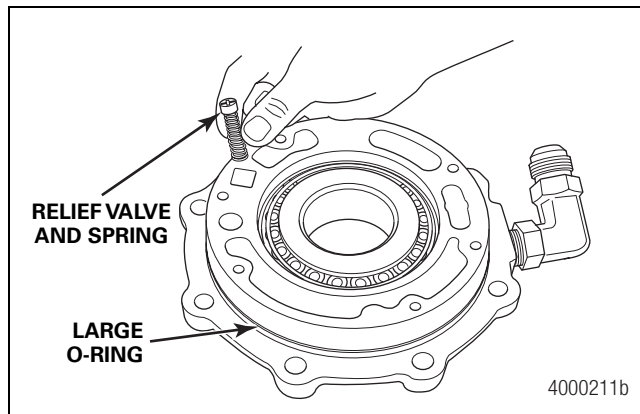

Figure 6.18

2. Pack grease into the pump oil inlet port before assembling the oil pump to the input bearing cage. Figure 6.19.

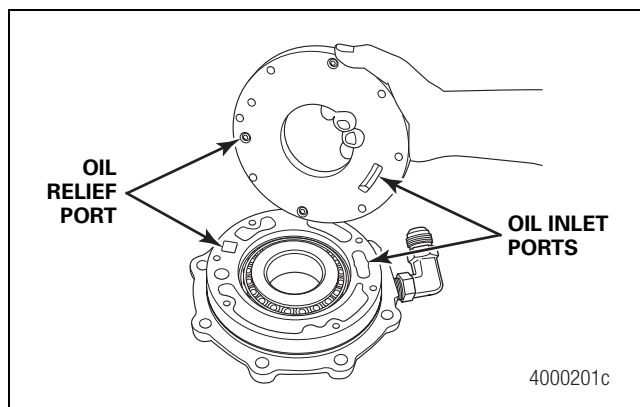



Figure 6.19

3. Place the bearing cone on the race in the bearing cage.
4. Insert the relief valve and spring into the relief port of the input bearing cage. Install the large diameter end of the spring down. Figure 6.18. Align the oil pump inlet with the oil inlet port of the input bearing cage. Figure 6.19.
5. Install the six pump-to-inlet bearing cage capscrews and washers. Apply Loctite® 277 sealant to the capscrews. Tighten the capscrews to 35-50 lb-ft (48-68 N•m). 

6. Place the small helical gear over the input shaft and install the spiral snap ring.
7. Lubricate the gear and shaft before assembly.
8. Lubricate the sealing rings on the inside diameter of the pump and the shaft journal adjacent to the pump splines. Figure 6.20.

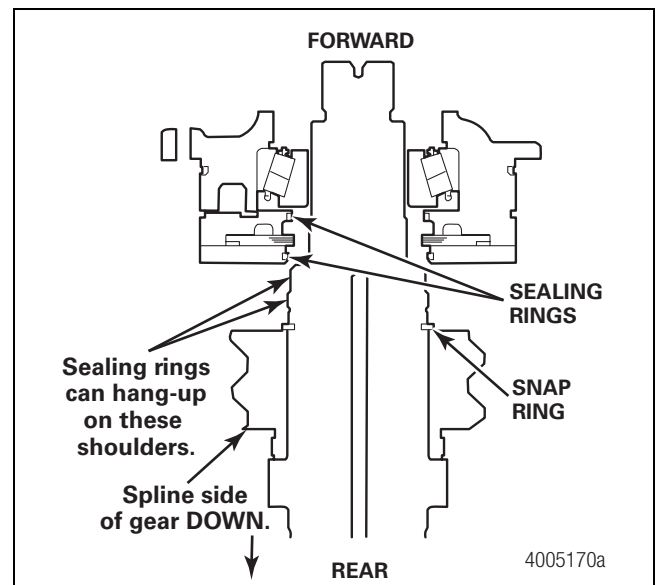

Figure 6.20

CAUTION

Exercise care when assembling the input shaft to the pump. Line up and slowly direct the input shaft into the pump opening. Misalignment during assembly can cause the shaft to “hang up” on the pump sealing rings resulting in damage to the rings.

9. Place the oil pump and input bearing cage assembly over the input shaft. The drive teeth on the inner pump rotor must engage the teeth on the input shaft. Do not use force to engage the splines. If a sealing ring is broken, remove and replace the pump.

6 Assembly

Input Seal Installation

⚠ WARNING

Solvent cleaners can be flammable, poisonous and cause burns. Examples of solvent cleaners are carbon tetrachloride, and emulsion-type and petroleum-base cleaners. Read the manufacturer's instructions before using a solvent cleaner, then carefully follow the instructions. Also follow the procedures below.

- Wear safe eye protection.
 - Wear clothing that protects your skin.
 - Work in a well-ventilated area.
 - Do not use gasoline, or solvents that contain gasoline. Gasoline can explode.
 - You must use hot solution tanks or alkaline solutions correctly. Read the manufacturer's instructions before using hot solution tanks and alkaline solutions. Then carefully follow the instructions.
1. If a seal sleeve is installed onto a yoke, remove the sleeve using a bearing puller. Do not reuse the seal sleeves.
 2. Inspect the yoke seal area for damage that could cause lubricant leaks after you install the seal. Use emery paper or an equivalent product to remove scratches, nicks or burrs only.
 3. Clean the ground and polished surface of the yoke journal using a clean shop towel and a safe cleaning solvent. Do not use abrasive cleaners, towels or scrubbers to clean the yoke or flange surface. Do not use gasoline.
 4. Inspect the yoke seal area for damage that could cause lubricant leaks after you install the seal. Use emery paper or an equivalent product to remove scratches, nicks or burrs only.

⚠ WARNING

Observe all warnings and cautions provided by the press manufacturer to avoid damage to components and serious personal injury.

Do not hit steel parts with a steel hammer. Pieces of a part can break off. Serious personal injury and damage to components can result.

5. Apply a light coat of axle oil to the yoke seal journal. Position the sleeve into the yoke sleeve driver. Do not touch the greased areas of the sleeve. The sleeve must be kept clean prior to assembly into the seal. Use an arbor press and the appropriate driver to install the sleeve into the yoke. Verify that the sleeve is fully seated in the yoke to prevent damage to components. Figure 6.21.

The yoke must be fully pressed into the sleeve driver until the end of the yoke bottoms out in the sleeve driver. This will correctly position the sleeve on the yoke. When correctly seated, the sleeve is positioned 0.030-inch \pm 0.030-inch (0.76 mm \pm 0.76 mm) from the end of the yoke. Figure 6.22.

- **If you do not have a press:** Position the yoke on a five-inch (127 mm) spacer on a workbench. Use a dead-blow hammer and the appropriate driver to install the sleeve into the yoke. Figure 6.23.

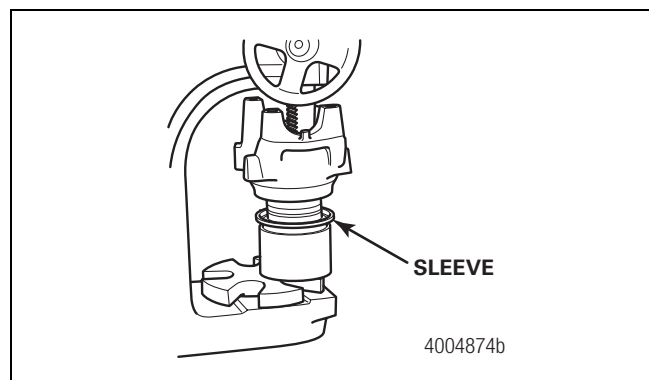

Figure 6.21

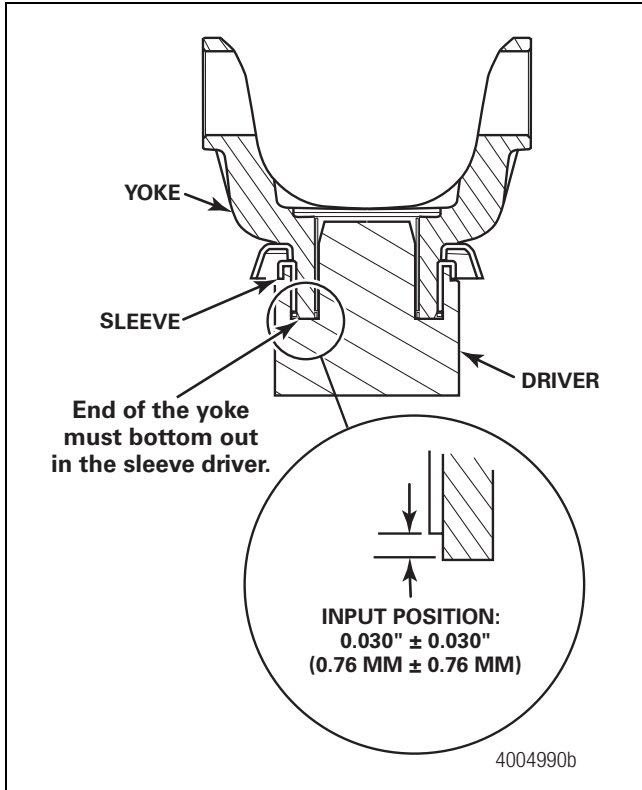

Figure 6.22

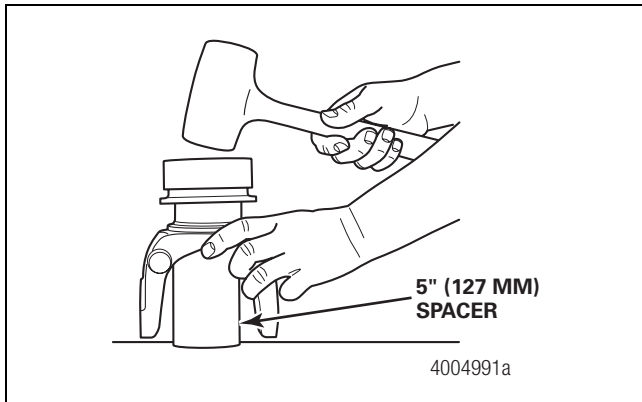

Figure 6.23

6. Install the input seal. Hold the sleeve and seal only on the outer diameter. Position the seal onto the input seal driver and align it with the shaft. Do not touch the lips in the inner diameter of the seal. Use a dead-blow hammer and the appropriate driver to install the seal onto the output shaft. Figure 6.24.

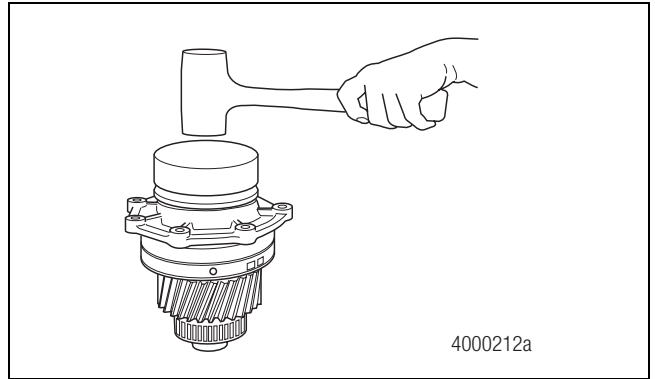

Figure 6.24

7. Use a feeler gauge to check the seal gap. The seal is correctly installed if the gap is less than 0.005-inch (0.127 mm) around the circumference of the seal flange.
 - If the gap is more than 0.005-inch (0.127 mm): Use a dead-blow hammer and the appropriate driver to completely install the seal.
8. Apply a light coat of transfer case oil to the yoke seal journal. Before installing the yoke, clean the splines of the old silastic. Apply a 1/8-inch (3.175 mm) bead of RTV 732 sealant 360 degrees around the outer two-inches (50.8 mm) of the yoke splines. Figure 6.25.

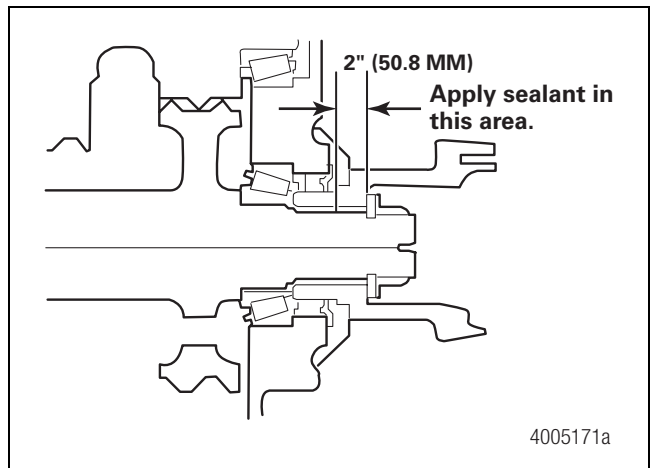





Figure 6.25

9. Install the yoke, washer and yoke nut. Loosely tighten the yoke nut at this time. Figure 6.25.

6 Assembly

Input Bearing Cage and Oil Pump Assembly Installation, Bearing End Play Adjustment and Transfer Case Final Assembly

1. Rotate the transfer case so that the front is facing UPWARD.
2. Position the shim pack for the input bearing cage and oil pump assembly over the front input opening. Position so that the open areas of the shims face the bottom of the transfer case.
3. Lubricate the input bearing cage large O-ring, oil pump, helical drive gear and bearing cone before installation. Use synthetic SAE 50 oil, Meritor specification O-81.
4. Install the input bearing cage and oil pump assembly. Position the assembly so that the inlet oil tube fitting is facing the correct direction.
5. Install at least three input bearing cage-to-housing capscrews. Tighten the capscrews to 85-115 lb-ft (115-156 N•m). 
6. **MTC-4208 and -4210 transfer cases only:** Install the large 3-inch (76 mm) diameter nut onto the rear end of the input shaft. Tighten the nut to 700-900 lb-ft (949-1220 N•m). 
7. Tighten the input shaft yoke nut to 700-900 lb-ft (949-1220 N•m). 
8. Set up a dial indicator to check input shaft bearing end play. Center the dial indicator over the shaft using a ball bearing for accuracy. Figure 6.26. If a sealing ring is broken, remove and replace the pump.

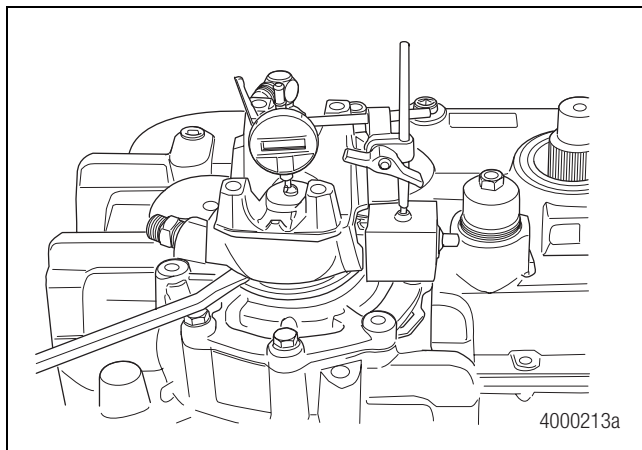



Figure 6.26

9. Use a pry bar to lift the yoke to obtain a measurement. To obtain a consistent and averaged reading, perform this operation two or three times. Record the reading for the input shaft.
 - **If the end play reading is greater than 0.001-0.005-inch (0.025-0.127 mm) for MTC-4208 and -4210 transfer cases, or 0.002 ±0.001-inch (0.025 mm) for the MTC-4213 transfer case:** Remove shims to decrease end play.
 - **If the end play reading is less than specification:** Add shims to increase end play. Bearing shims come in 0.003-, 0.005- and 0.010-inch (0.08, 0.13 and 0.25 mm) thicknesses.
10. If it is necessary to add or remove shims, remove the input bearing cage and oil pump assembly capscrews and lift the assembly enough to insert or remove shims.
 - This can be done without completely removing the pump and shaft assembly from the housing.
 - The nut on the rear end of the shaft on MTC-4208 and -4210 transfer cases must be removed first. Refer to the exploded views in this manual.
11. When the correct shim pack is chosen, reinstall all seven input bearing cage and oil pump assembly capscrews. Tighten the capscrews to 85-115 lb-ft (115-156 N•m). 
12. Recheck the input shaft bearing end play. Adjust the end play as necessary.
13. If necessary, install the breather into the rear cover. Figure 6.27.

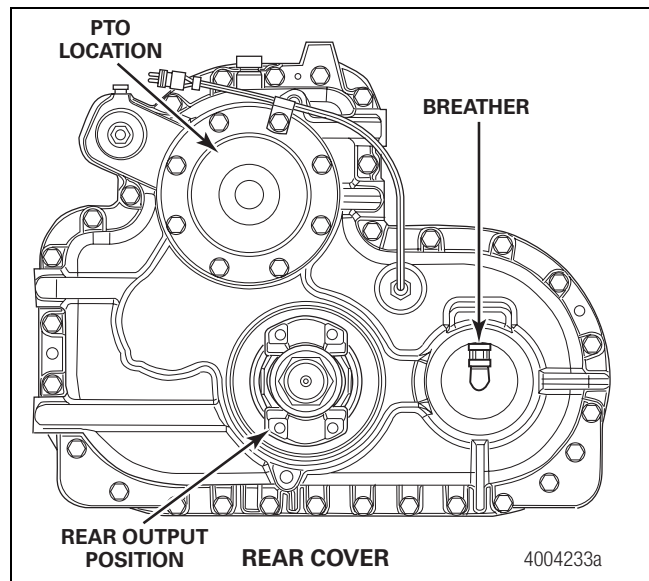



Figure 6.27

14. Install the oil inlet tube to the lower and upper fittings. Tighten the fitting nuts to 35-40 lb-ft (48-54 N•m). Figure 6.28. 

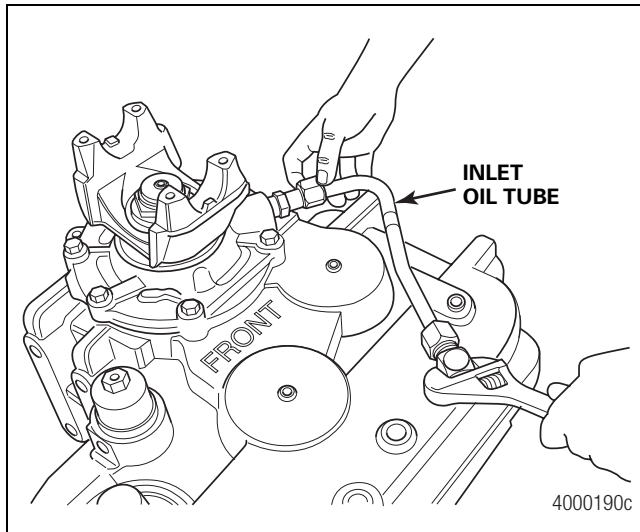

Figure 6.28

15. If removed, install the speed sensor into the top of the transfer case. Figure 6.29. Fasten with a capscrew and washer.

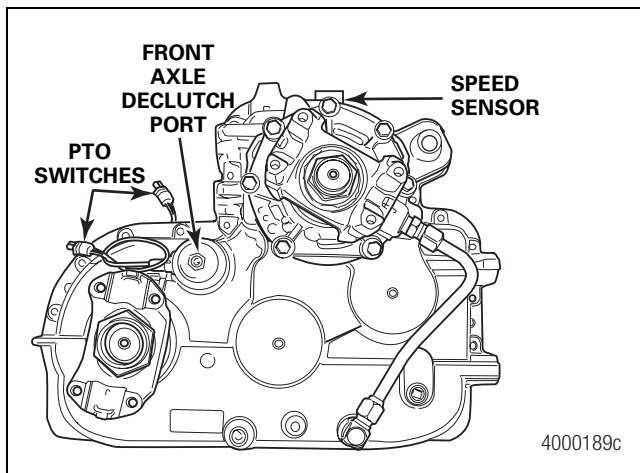



Figure 6.29

16. Install the PTO engagement and disengagement switch assemblies, if equipped. Otherwise, install a nut and washer into the open port.
17. Reinstall all other pipe threaded plugs using Loctite® 592 sealant.

Oil Cooler Ready Model Only

1. Reinstall the male connector fittings, if removed. Apply Loctite® 592 threadlocker to the pipe threads. Tighten the fittings to 25 lb-ft (34 N•m). 
2. Connect the oil cooler lines.
 - **If the vehicle is not equipped with an oil cooler:** Reconnect the loop line. Tighten the fittings to 20 lb-ft (27 N•m). 

Transfer Case Shifting Check

1. Apply 60 psi (4.14 bar) or greater of air pressure to the front axle declutch. Figure 6.29.
2. Turn the input shaft by hand to verify that the front output turns at same rate as the rear output.
3. Remove the air pressure.
4. Apply 60 psi (4.14 bar) or greater of air pressure to the high-range shaft air port. Figure 6.30.

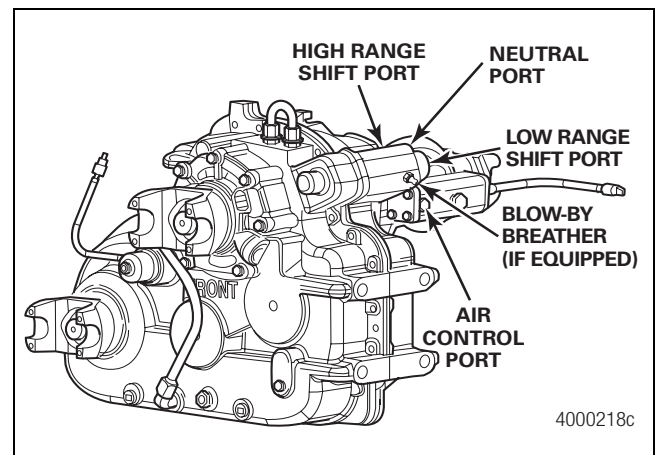



Figure 6.30

5. Turn the input shaft by hand to verify that the rear output turns at same rate as the input.
6. Remove the air pressure.
7. Apply 60 psi (4.14 bar) or greater of air pressure to the low-range shaft cylinder air port. Figure 6.30.
8. Turn the input shaft by hand to verify that the rear output turns at approximately half the rate as the input.
9. Remove the air pressure.

6 Assembly

10. For PTO-equipped cases, apply 60 psi (4.14 bar) or greater of air pressure to the neutral shift location. Figure 6.30.
11. Turn the input shaft by hand to verify that the rear output does not turn at all. Have someone hold the output shafts to prevent them from turning while spinning the input.
12. Remove the air pressure.
13. Remove the transfer case from the stand.
14. With the transfer case UPRIGHT, fill the transfer case with the required lubricant to the fill hole level. Refer to Table G for volume.

Adjust the Oil Level

1. Clean the area around the fill plug. Remove the fill plug from the transfer case.
2. Add the specified oil until the oil level is even with the bottom of the fill plug hole.
3. Install and tighten the fill plug to 35-50 lb-ft (47-68 N•m). 
4. Test drive the vehicle for at least one mile (1.6 km). Allow the oil to settle for five minutes and recheck the fluid level. Top off the oil level by adding oil to the fill opening. Reinstall and tighten the fill plug to 35-50 lb-ft (47-68 N•m). 

WARNING

Failure to correct an oil leak or operating the transfer case low on oil could result in damage to the transfer case. In addition, overfilling the oil level will cause excessive heat and damage to the transfer case.

CAUTION

Use only SAE Grade 50W full synthetic oil in the transfer case. Do not use multi-viscosity engine oils or Extreme Pressure (EP) GL-5 gear oils. Damage to components can result. Refer to publication TP-90114, Transmission Lubricant Specifications, for a list of approved distributors.

Transfer Case Assembly Test

CAUTION

The air pressure must not exceed 10 psi (0.69 bar). Damage to components can result.

1. Pressure test the transfer case assembly for air leakage.
2. Check that the fittings are installed correctly.
3. Remove the breather assembly. Figure 6.27.
4. With the correct fitting installed into the breather port, apply a pressure of 8-10 psi (0.55-0.69 bar).
5. Shut the air supply off.
 - **If the pressure decreases by more than 2 psi (0.14 bar) in 10 minutes:** Check for external leaks at the fittings.
6. Correct the leakage problem and retest.
7. Reinstall the breather assembly.

Hazard Alert Messages

Read and observe all Caution and Warning safety alerts below and those that precede instructions or procedures you will perform.

WARNING

To prevent serious eye injury, always wear safe eye protection when you perform vehicle maintenance or service.

When you apply some silicone gasket materials, a small amount of acid vapor is present. To prevent serious personal injury, ensure that the work area is well-ventilated. Read the manufacturer's instructions before using a silicone gasket material, then carefully follow the instructions. If a silicone gasket material gets into your eyes, follow the manufacturer's emergency procedures. Have your eyes checked by a physician as soon as possible.

Take care when you use Loctite® adhesive to avoid serious personal injury. Read the manufacturer's instructions before using this product. Follow the instructions carefully to prevent irritation to the eyes and skin. If Loctite® adhesive material gets into your eyes, follow the manufacturer's emergency procedures. Have your eyes checked by a physician as soon as possible.

Observe all warnings and cautions provided by the press manufacturer to avoid damage to components and serious personal injury.

Park the vehicle on a level surface. Block the wheels to prevent the vehicle from moving. Support the vehicle with safety stands. Do not work under a vehicle supported only by jacks. Jacks can slip and fall over. Serious personal injury and damage to components can result.

Installation

This section provides instructions on installing a power take-off (PTO) assembly onto Meritor MTC-4208 and -4210 transfer cases using Kit 2540. Refer to Table C and Figure 7.1. Refer to the Service Notes page on the front inside cover of this manual to obtain this Kit.

Table C: Kit 2540

Part Name	Qty.	Part Number	Description
PTO Assembly	1	MDP-10-AF-100	10,000 lb-ft (13 500 N•m) torque rating
Washer	8	1229-E-1513	0.81" O.D. x 0.47" I.D. x 0.09" thickness
Capscrew	6	S-2710-2	7/16" - 14 thread x 1.25" long
Capscrew	2	S-2746-2	7/16" - 14 thread x 5.75" long
Washer	1	1229-T-1736	2.36" x 1.56 I.D. x 0.12" thickness
Locknut	1	40-X-1237	M39 x 1.5 thread
Dowel Pin	2	1246-T-1190	3/8" diameter x 1" long

7 Power Take-Off (PTO)

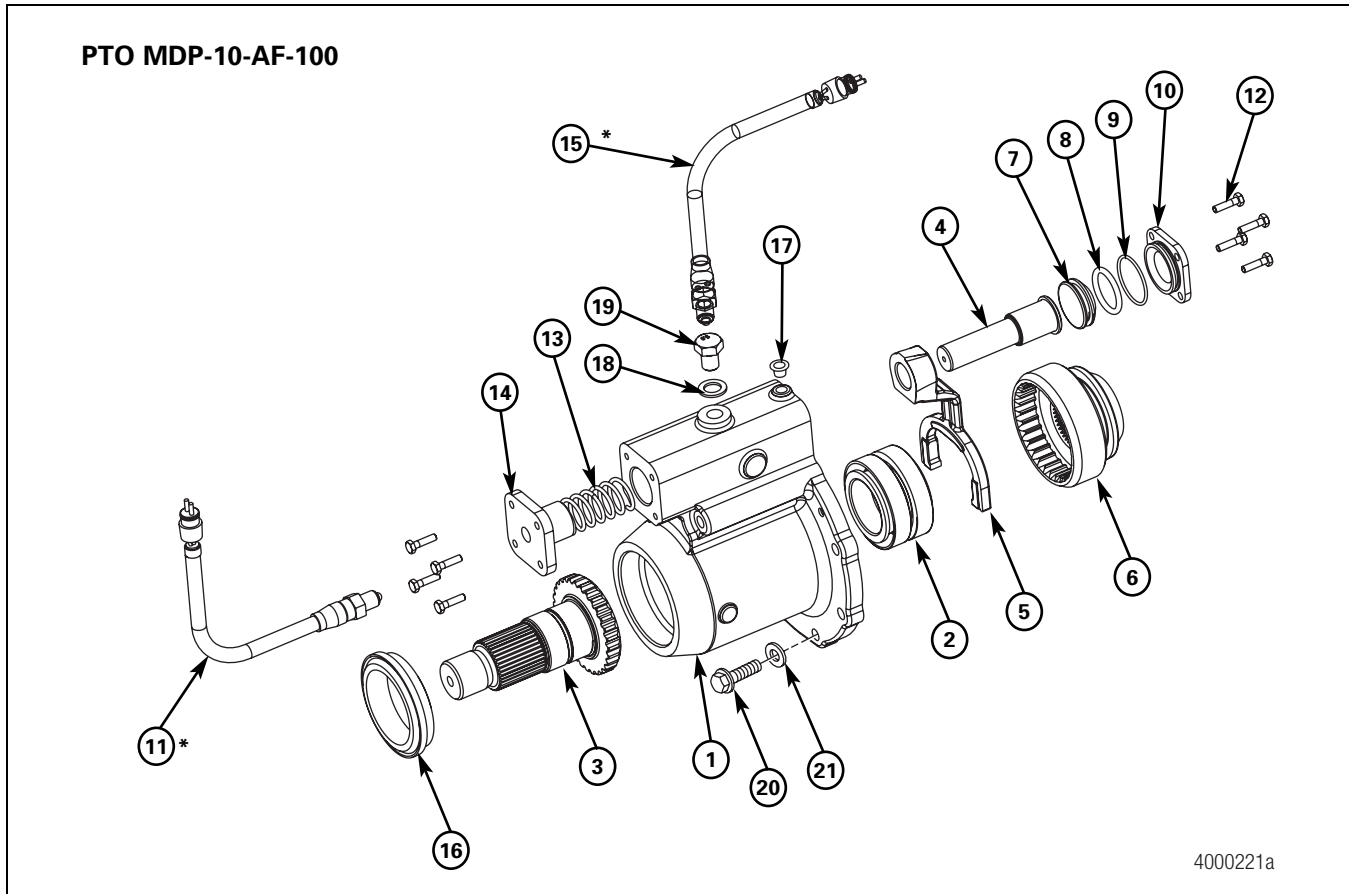

Figure 7.1

Item	Description	Qty.	Item	Description	Qty.
1	Bearing Cage	1	12	Capscrew	1
2	Bearing Assembly	1	13	Shifter Spring	1
3	PTO Shaft	1	14	Cap	1
4	Push Rod	1	15*	Declutch Switch Assembly	1
5	Shift Fork	1	16	Oil Seal Assembly	1
6	Differential Lockout Collar	1	17	Shipping Protector	1
7	Shifter Piston	1	18	Flat Washer	2
8	O-Ring, 1.46-inch (37 mm) Diameter	1	19	Special Screw	2
9	O-Ring, 1.80-inch (46 mm) Diameter	1	20	Capscrew, 1.25-inch (32 mm) Long	6
10	Cover Plate	1	20	Capscrew, 5.75-inch (146 mm) Long	2
11*	Switch Assembly, Standard	1	21	Washer	8

* Optional

Remove the Transfer Case Rear Access Cover

1. Park the vehicle on a level surface. Block the wheels to prevent the vehicle from moving.
2. Remove the air from the vehicle's system.
3. Place a suitable container under the transfer case to catch the hydraulic fluid that will drain when you remove the rear access cover.

4. Remove the eight mounting bolts and washers that secure the transfer case rear access cover. Remove the cover. Figure 7.2.
5. Clean the PTO mounting surface to remove all sealant.

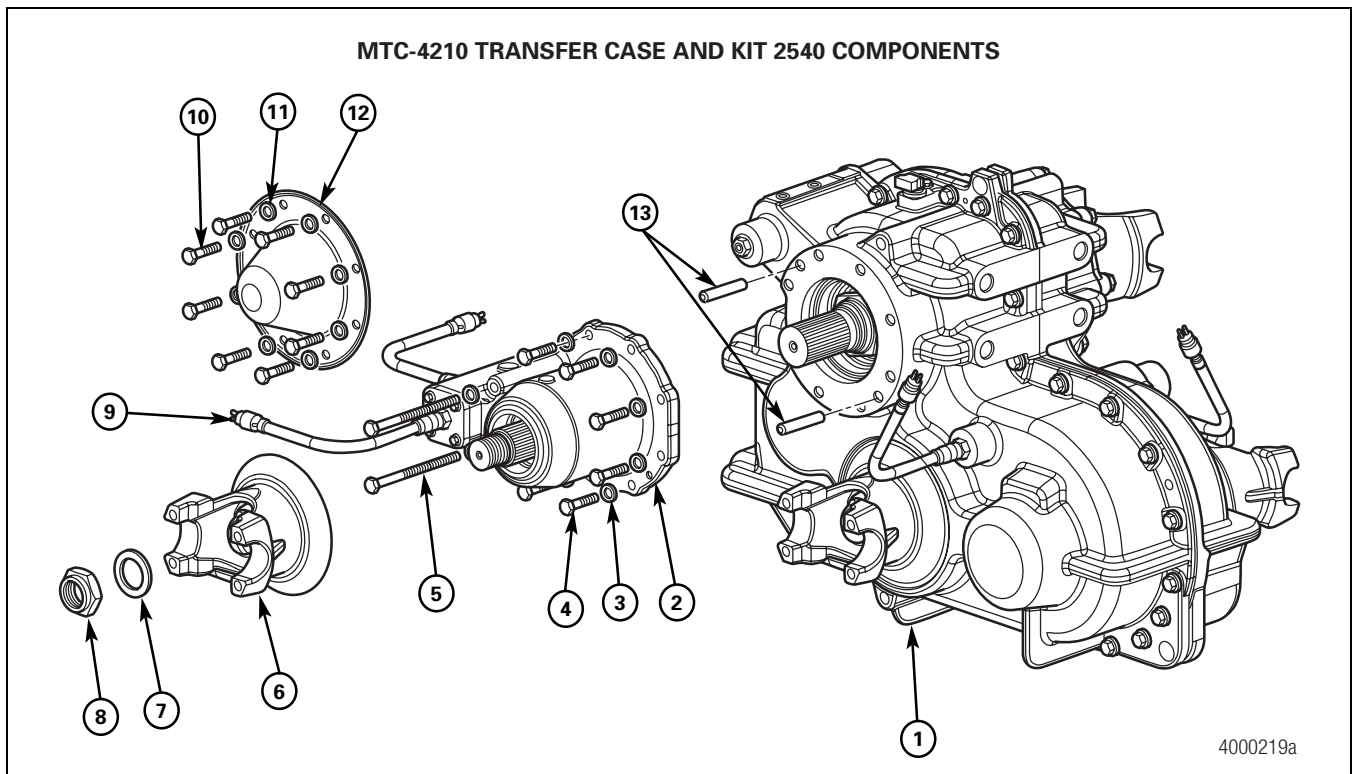

Figure 7.2

Item	Description
1	Transfer Case
2*	PTO Assembly
3*	Washer, 0.47-inch (12 mm) Inside Diameter
4*	Capscrew, 1.25-inch (32 mm) Long
5*	Capscrew, 5.75-inch (146 mm) Long
6	Yoke
7*	Washer, Yoke Mounting
8*	Locknut, Yoke Mounting

* Kit 2540 component

Item	Description
9	Switch and Connector Assembly
10	Bolt, Rear Access Cover
11	Washer, Rear Access Cover
12	Cover, Rear Access
13*	Dowel Pin

7 Power Take-Off (PTO)

Install the Yoke Onto the PTO

You must install a Meritor yoke with the spline code "RAI" onto the PTO. For yoke options, refer to Table D and Figure 7.3.

Table D: PTO Yoke Options and Dimensions

Part Number	Yoke Description	Dimensions					
		Inches (Millimeters)					
		A	B	C	D	E	F
17NYS32-100A1	Full Round	Center to End	Spline Length	Hub Diameter	Bearing Diameter	Across Ears	Spline Size
17TYS32-68A1	Easy Service™	Center to End	Spline Length	Hub Diameter	Bearing Diameter	Across Ears	Spline Size
		5.16 (131)	2.32 (59)	3.00 (76)	1.94 (49)	6.00 (152)	2.00 x 39 (51 x 991)
		5.47 (139)	2.32 (59)	3.00 (76)	1.94 (49)	6.20 (157)	2.00 x 39 (51 x 991)

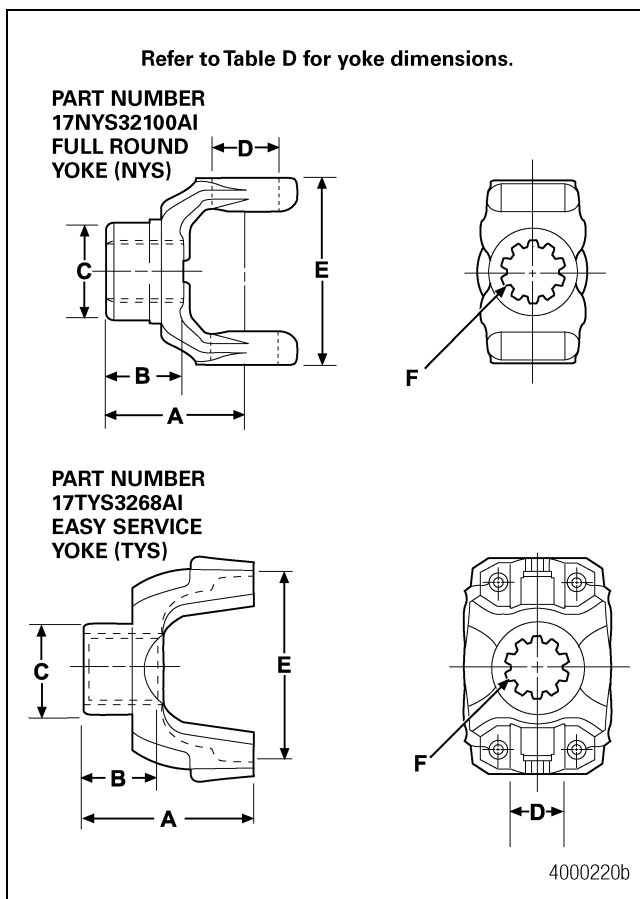

Figure 7.3

1. Use a press and an applied press force of 500-1500 lbs (227-680 kg) to install a Meritor yoke, spline code RAI, onto the PTO shaft. Figure 7.2.

2. Apply a 1.8-inch (46 mm) bead of RTV silicone gasket material around the end of the yoke spline under the washer surface.
3. Install the washer and locknut supplied in the kit. Tighten the locknut to 700-900 lb-ft (949-1220 N•m).

Install the Optional Indicator Switch

You must install the optional PTO switch listed in Table E.

Table E: PTO Switch Option

Part Name	Qty.	Part Number	Description
Switch and Connector Assembly	1	3237-W-1167	2 Amp x 12 VDC, M16 x 1" thread

1. Remove the screw and washer from the end of the PTO cap. Figure 7.4.

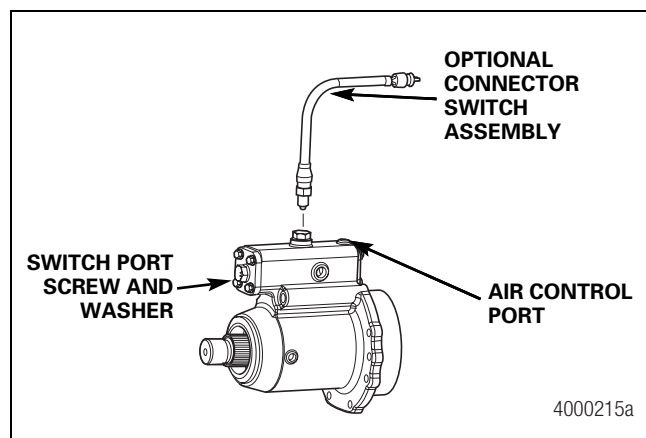



Figure 7.4

2. Apply Loctite® 518 gasket sealant to the indicator switch threads.
3. Install the indicator switch. Tighten the switch to 25-30 lb-ft (34-41 N•m). Figure 7.5. 

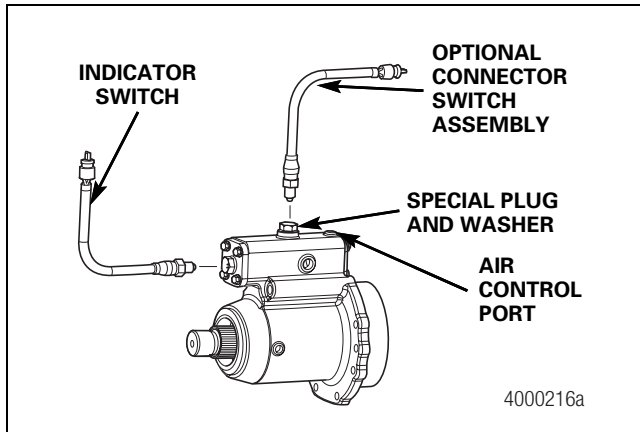



Figure 7.5

Install the PTO Onto the Transfer Case

1. Install two dowel pins into the transfer case PTO flange.
2. Apply a thin coating of Loctite® 518 gasket sealant to the entire PTO flange mounting surface. Figure 7.2.
3. Slide the PTO assembly onto the output shaft spline. Align the assembly to the two dowel pins.
4. Install the washers and mounting bolts. Tighten the bolts to 60-75 lb-ft (81-102 N•m). 
5. Install the PTO air control line and fitting. Follow the vehicle manufacturer's instructions.

Test the PTO Installation

CAUTION

The PTO clutch must be engaged to operate the drive. Always engage and disengage the PTO with the vehicle stationary and in Neutral. Do not apply a load to the PTO drive until the drive has been engaged. Damage to components can result.

The air pressure must not exceed 90 psi (6.2 bar). Damage to components can result.

1. Connect a regulated air pressure line to the air control port. Figure 7.6.

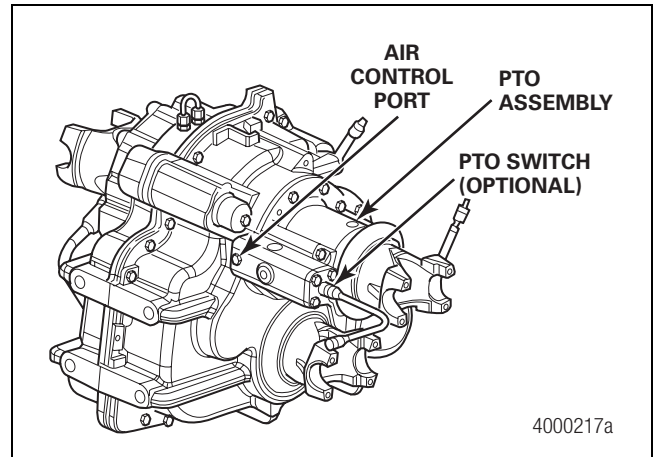

Figure 7.6

2. Apply 90 psi (6.2 bar) of air pressure.
3. Check for leaks in the PTO air control line.
4. Cycle the air control pressure. Follow the procedures below to check that the PTO clutch engages correctly.

PTO Without an Optional Indicator Switch

1. Remove the switch port screw and washer. Figure 7.4.
2. Measure the PTO push rod travel to verify that the travel is 0.75-inch (19 mm) and that the clutch is fully engaged.
 - **If the push rod travel is not at 0.75-inch (19 mm) and the PTO clutch is not fully engaged:** Disengage the clutch by releasing the air pressure. Rotate the clutch output shaft by hand and retest.
 - **If the clutch still is not fully engaged:** Remove the PTO assembly. Check the transfer case output shaft splines and the PTO clutch collar splines. Replace worn or damaged parts. Repeat the assembly procedures.

7 Power Take-Off (PTO)

PTO with an Optional Indicator Switch

1. Install the indicator switch. Tighten the switch to 25-30 lb-ft (34-40.8 N•m). 
2. Verify that the indicator switch closes when the PTO completes a shift to engage the drive. Figure 7.5.
 - **If the indicator switch does not close to fully engage the drive:** Measure the PTO push rod travel to verify that the travel is 0.75-inch (19 mm) and that the clutch is fully engaged.
 - **If the push rod travel is not at 0.75-inch (19 mm) and the PTO clutch is not fully engaged:** Disengage the clutch by releasing the air pressure. Rotate the clutch output shaft by hand and retest.
 - **If the clutch still is not fully engaged:** Remove the PTO assembly. Check the transfer case output shaft splines and the PTO clutch collar splines. Replace worn or damaged parts. Repeat the assembly procedures.

Test the Transfer Case with the PTO Assembly Installed

CAUTION

The air pressure must not exceed 10 psi (0.69 bar). Damage to components can result.

1. Connect a regulated air pressure line to the air transfer case breather. Figure 7.7.

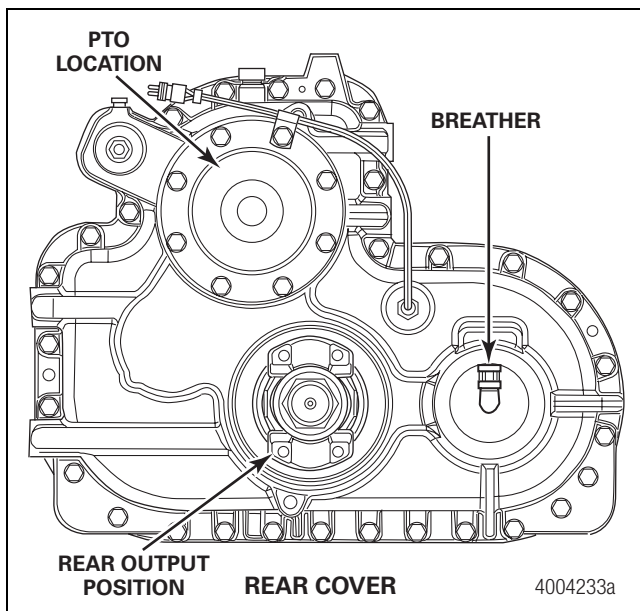

Figure 7.7

2. Check that the air pressure line fittings are installed correctly.
3. With the correct fitting installed into the breather port, apply a pressure of 8-10 psi (0.55-0.69 bar).
4. Turn the air supply OFF. Check the pressure.
 - **If the pressure decreases by more than 2 psi (0.14 bar) in 10 minutes:** Check for external leaks at the fittings. Correct any leaks. Recheck the pressure.
5. Install the breather.

PTO Assembly

1. Rotate the transfer case in the repair stand so that the output shaft to the PTO is facing UPWARD.

CAUTION

The cups must fit securely in the housing bores. Damage to the components can result.

2. Assemble the PTO components by performing the following steps.
 - A. Install the bearing cups into the PTO bearing cage housing. This is an interference fit. Freeze the bearing to -65°F (-54°C) and position the two cups into the housing bores. Figure 7.8.
 - **If the cups are loose after the cup temperature warms:** Replace the housing.

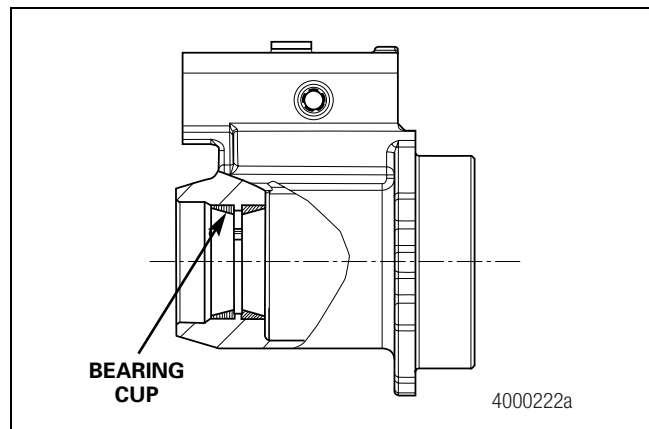

Figure 7.8

7 Power Take-Off (PTO)

- B. Preheat the first bearing cone to 200° F (93° C). Support the shaft and slide the heated cone in place onto the output shaft. Figure 7.9.

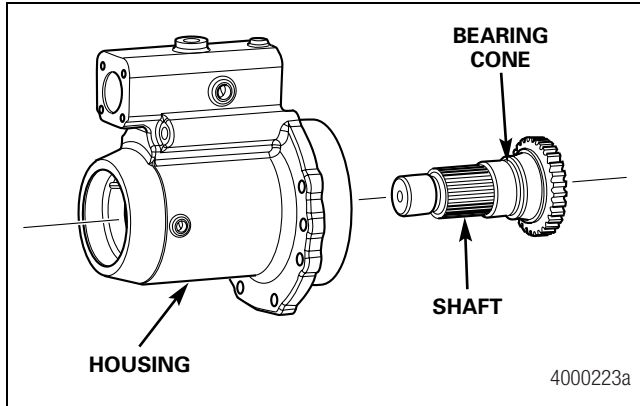

Figure 7.9

- C. Install the shaft assembly into the housing. Slide the bearing spacer onto the splined end of the shaft.
- D. With the bearing spacer in position, the second bearing cone can be heated to 200° F (93° C) and installed onto the shaft. Figure 7.10.

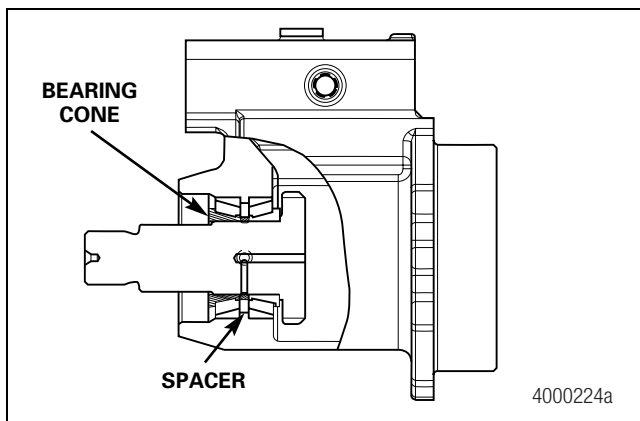

Figure 7.10

- E. Support the shaft and apply a press of 50-60 lbs (23-27 kg) to the bearing cone to set the bearing in place while the bearing cools.
- F. Apply a light film of SAE 50W synthetic lubricant.
- G. Assemble the shift fork to the clutch collar. Install this unit into the bearing cage housing.
- H. Install the push rod into the housing and through the shift fork assembly.

- I. Apply 20-30 lbs (9-14 kg) of pressure to insert the piston into the housing. Figure 7.11.

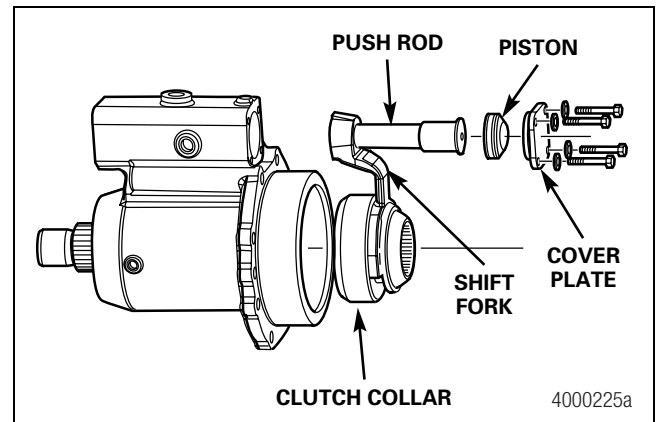



Figure 7.11

- J. Install the cover plate with the O-ring seal in place.
- K. Lightly lubricate all parts with SAE 50W synthetic lubricant.
- L. Install the 1/4-20 screws using Loctite® 242 sealant. Tighten the screws to 10-14 lb-ft (14-19 N•m). 
- M. Insert the spring into the housing over the push rod. Figure 7.12.

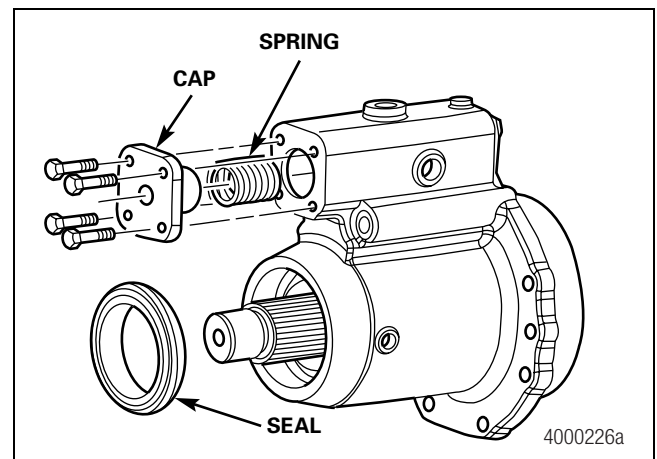



Figure 7.12



- N. Apply a thin film of Loctite® 518 gasket material to the cap surface. Install the cap with the 1/4-20 screws using Loctite® 242 sealant. Tighten the screws to 10-14 lb-ft (14-19 N•m). Figure 7.12. 
- O. Install the PTO shaft seal into the housing.
- P. Press the seal into position until the seal is seated on the housing.

7 Power Take-Off (PTO)

3. Install the PTO assembly onto the transfer case.
4. Apply a thin film of Loctite® 518 gasket material to the housing.
5. Slide the housing onto the output shaft of the transfer case, aligning the splines of the clutch to the shaft.
6. Install the eight 7/16-inch (11 mm) diameter screws and washers using Loctite® 277 sealant. Tighten the screws to 60-75 lb-ft (81-102 N•m). 
7. Check that the clutch engages and disengages correctly.
8. Pressure test the PTO shifter for air leakage by performing the following steps.
 - A. With the correct fitting installed into the air control port, apply a pressure of 90 psi (6.2 bar).
 - B. Shut off the air supply.

CAUTION

Check for external leaks at the cover plate joint and fitting if the pressure decreases more than 5 psi (0.3 bar) in 10 minutes. Leaks can cause component damage.

- C. Check for external leaks at the cover plate joint and fitting if the pressure decreases more than 5 psi (0.3 bar) in 10 minutes.
 - **If the external joints are sealed and the leakage is still more than 5 psi (0.3 bar):** Remove the piston and inspect the O-ring and housing bore for damage. Repair parts as necessary.
9. Install the indicator switch. Tighten the switch to 25-30 lb-ft (34-40 N•m). Figure 7.13. 
 - **If a switch is not used:** Install the special plug and washer used to cap the access hole. Tighten the plug to 25-30 lb-ft (34-40 N•m). Figure 7.13. 

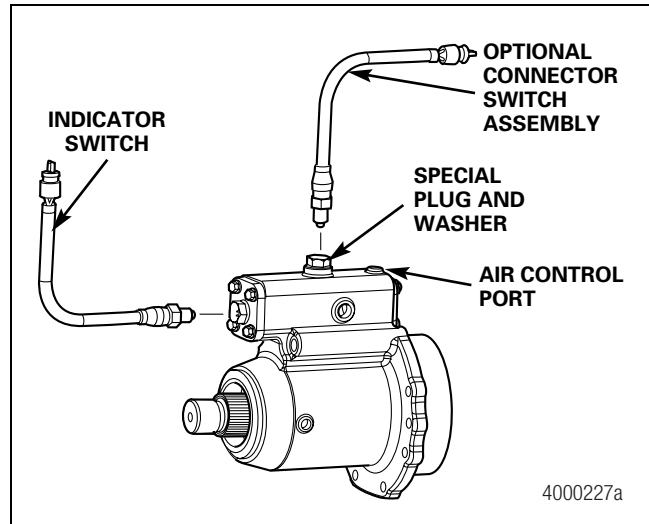

Figure 7.13

10. Repeat Step 1 through Step 9 for each remaining declutch, PTO or proportional differential lockout assemblies.

Hazard Alert Messages

Read and observe all Warning and Caution hazard alert messages in this publication. They provide information that can help prevent serious personal injury, damage to components, or both.

⚠ WARNING

To prevent serious eye injury, always wear safe eye protection when you perform vehicle maintenance or service.

Install the Transfer Case

⚠ WARNING

Support the transfer case with a lifting device before moving the transfer case. A transfer case that is not supported correctly can fall. Serious personal injury and damage to components can result.

1. Use a lifting device to move the transfer case from the repair stand to a hydraulic roller jack. If used, remove the temporary eye-bolts and angle iron brackets from the transfer case housing.
2. Move the transfer case into position under the vehicle with the hydraulic roller jack.
3. Install the transfer case into the vehicle with the mounting bolts. Tighten the bolts to the torque specification supplied by the vehicle manufacturer.
4. Connect the drivelines to the input and output yokes of the transfer case.
5. Connect any switch or speed sensor wiring.
6. Fill the transfer case with correct quantity of specified lubricant. Refer to Maintenance Manual 1, Preventive Maintenance and Lubrication. To obtain this publication, refer to the Service Notes page on the front inside cover of this manual.

Check and Adjust the Oil Level

⚠ CAUTION

Only use new lubricant when you change or adjust the oil in the transfer case. Do not reuse lubricant, which can contain metallic particles and other contaminants. Damage to components can result.

NOTE: Use only SAE Grade 50W oil, Meritor specification O-81, in the transfer case.

1. Park the vehicle on a level surface.

2. Clean the area around the fill plug. Remove the fill plug from the transfer case. Figure 8.1. The oil level must be even with the bottom of the fill plug hole.
 - **If oil flows from the hole when you loosen the plug:** The oil level is high. Drain the oil to the bottom of the fill hole.
 - **If the oil level is below the bottom of fill/level plug hole:** Add the specified oil until oil is even with the bottom of the fill hole.
3. Install and tighten the fill plug to 35-50 lb-ft (47-68 N•m). **ⓘ**
4. Test drive the vehicle for at least one mile (1.6 km). Allow the oil to settle for five minutes and recheck the fluid level. Top off the oil level by adding oil to the fill opening. Reinstall and tighten the fill plug to 35-50 lb-ft (47-68 N•m). **ⓘ**

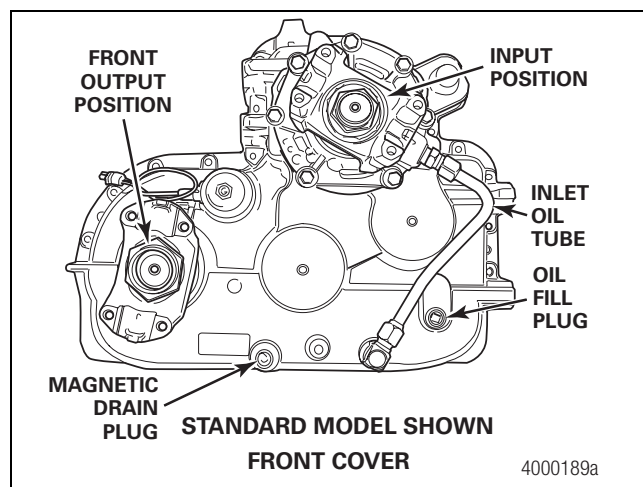

Figure 8.1

⚠ CAUTION

Do not operate the transfer case if the oil level is below the bottom of the fill hole, which may be an indication that the transfer case is leaking. Damage to components can result. If the transfer case is leaking, repair the leak. Adjust the oil level before returning the transfer case to service.

When servicing the transfer case, add the specified lubricant until the oil level is even with the fill hole. Do not overfill the transfer case, which can cause the transfer case to overheat. Damage to components can result.

Meritor does not approve petroleum-based and multiviscosity oil. Do not install API GL-5 oils, which contain extreme-pressure (EP) additives. These additives can form sludge at normal operating temperatures. Damage to components can result. Use only SAE Grade 50W synthetic oil in the transfer case.

Troubleshooting

Transfer Case Lubrication Diagnostics

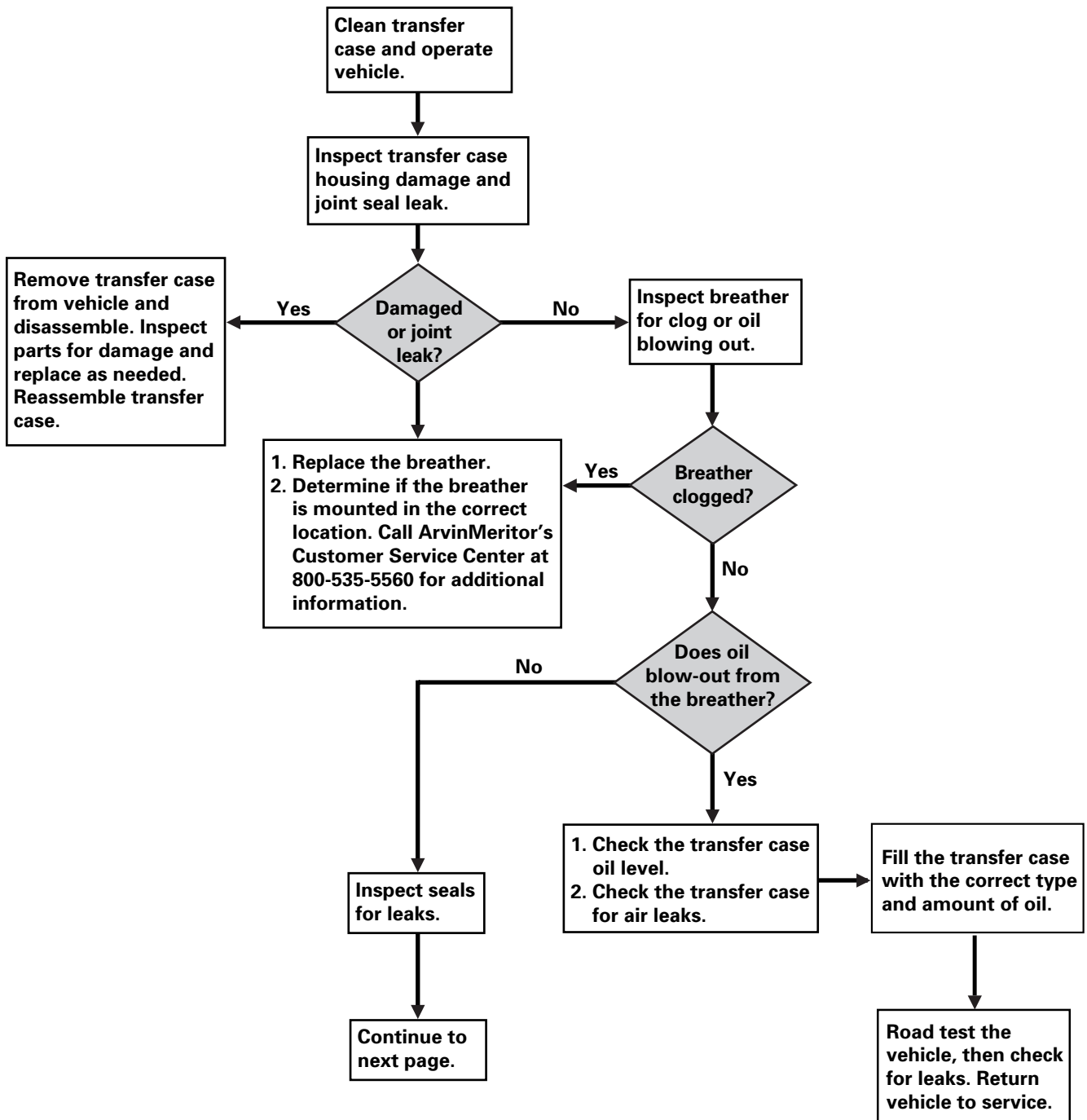

4001525b

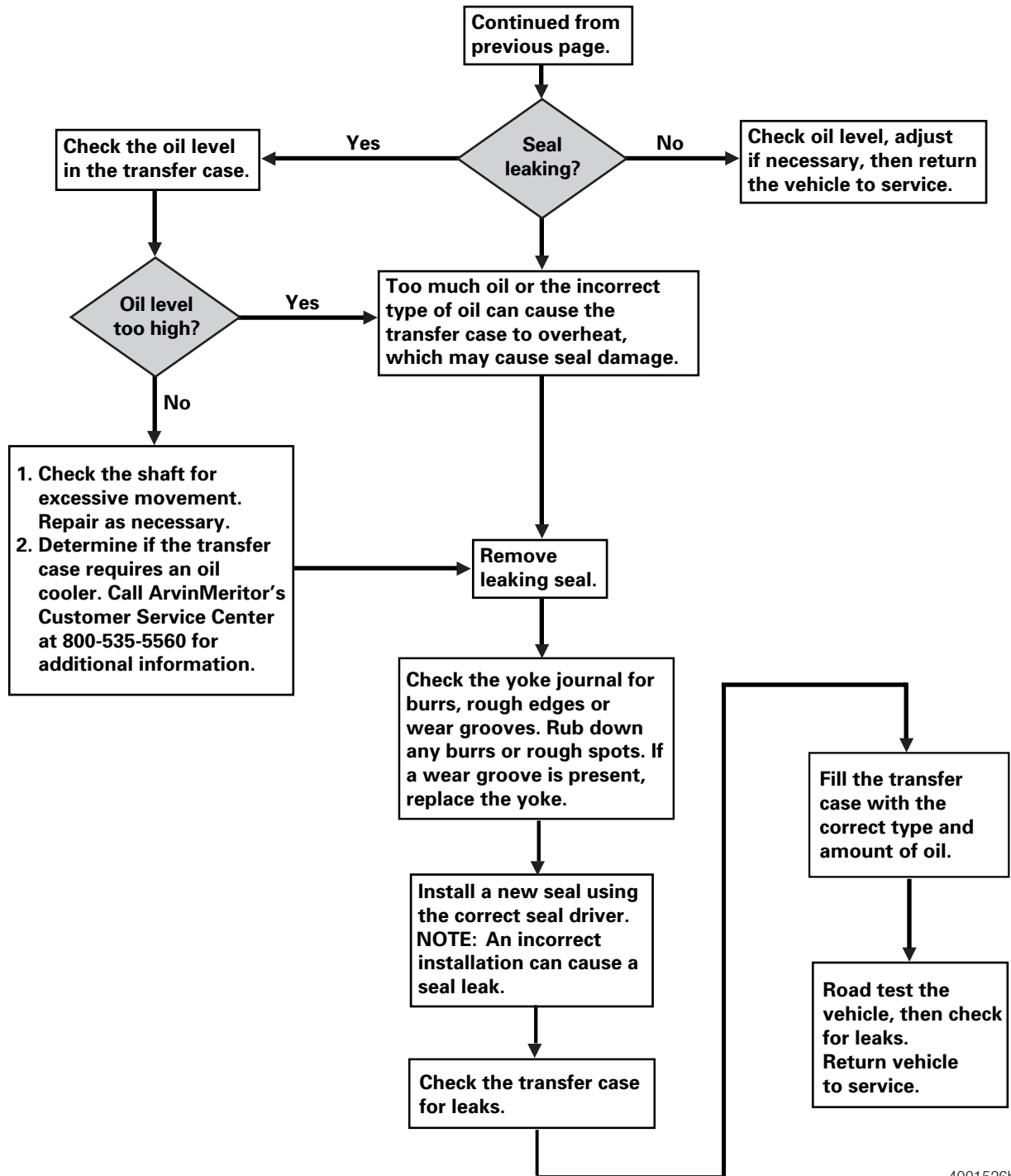

4001526b

Excessive Noise and Vibration Diagnostics

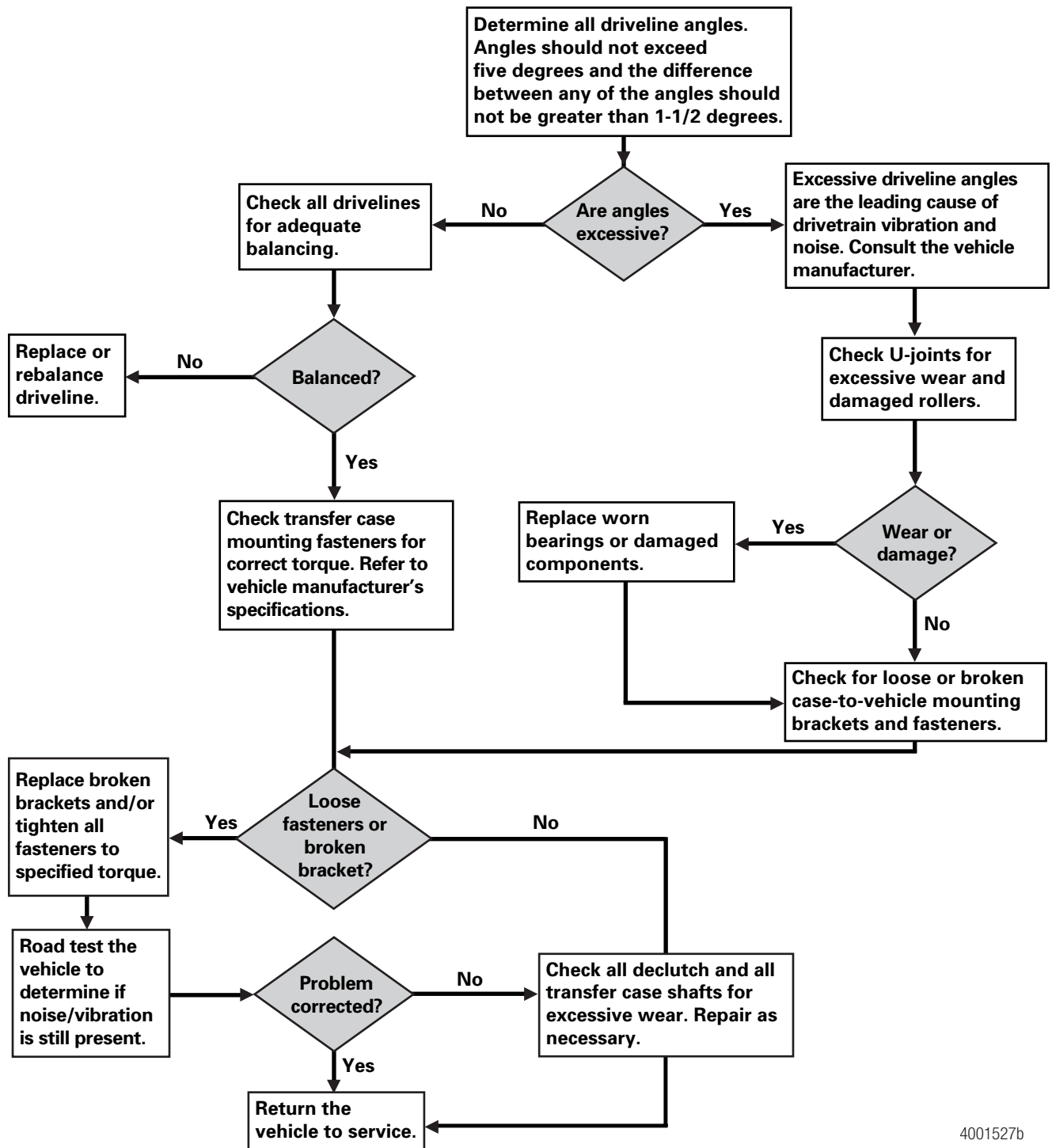

4001527b

PTO Does Not Engage/Disengage Diagnostics

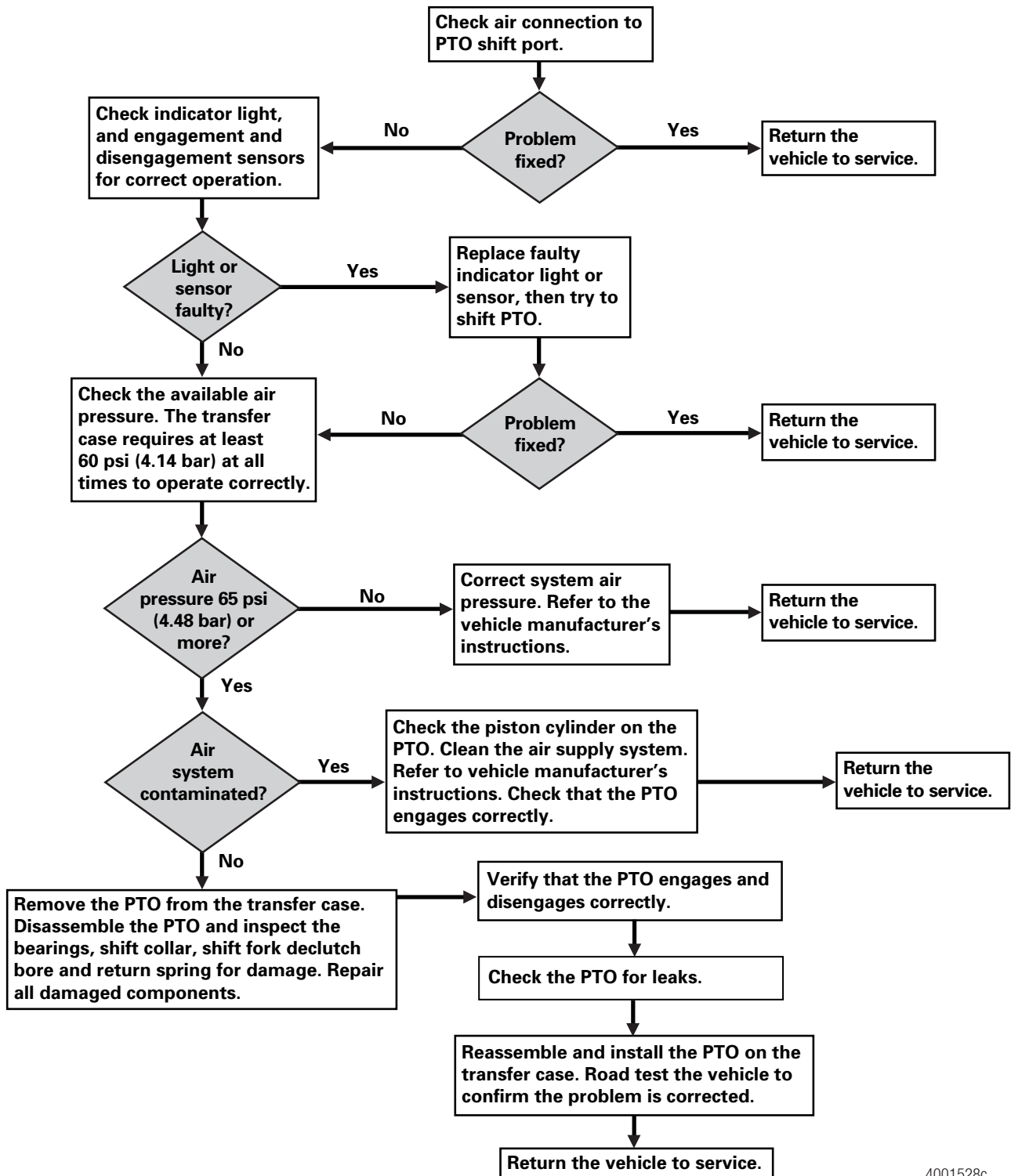

4001528c

Front Axle Declutch Does Not Engage/Disengage Diagnostics

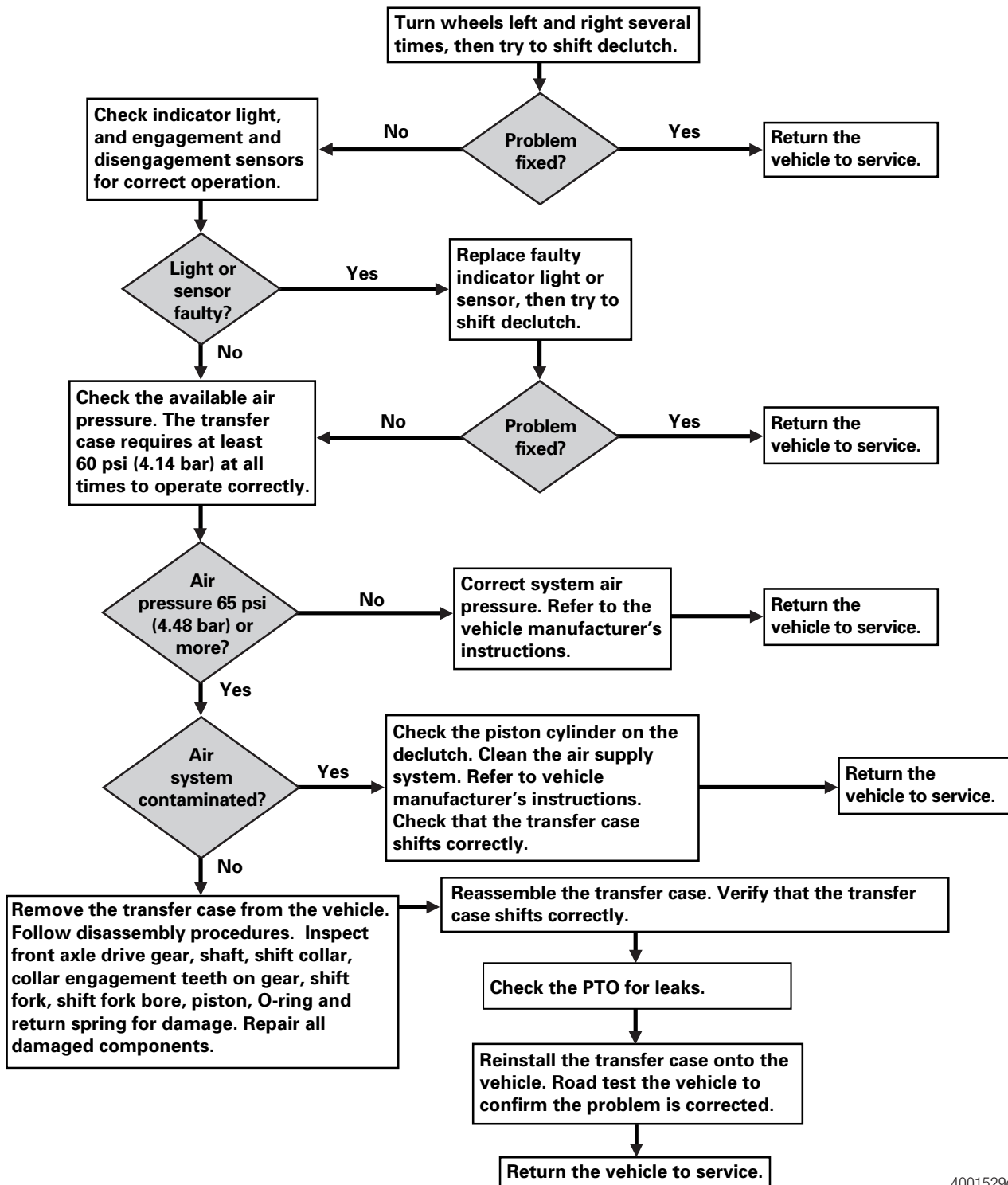

4001529c

High/Low Gear Shifting Diagnostics

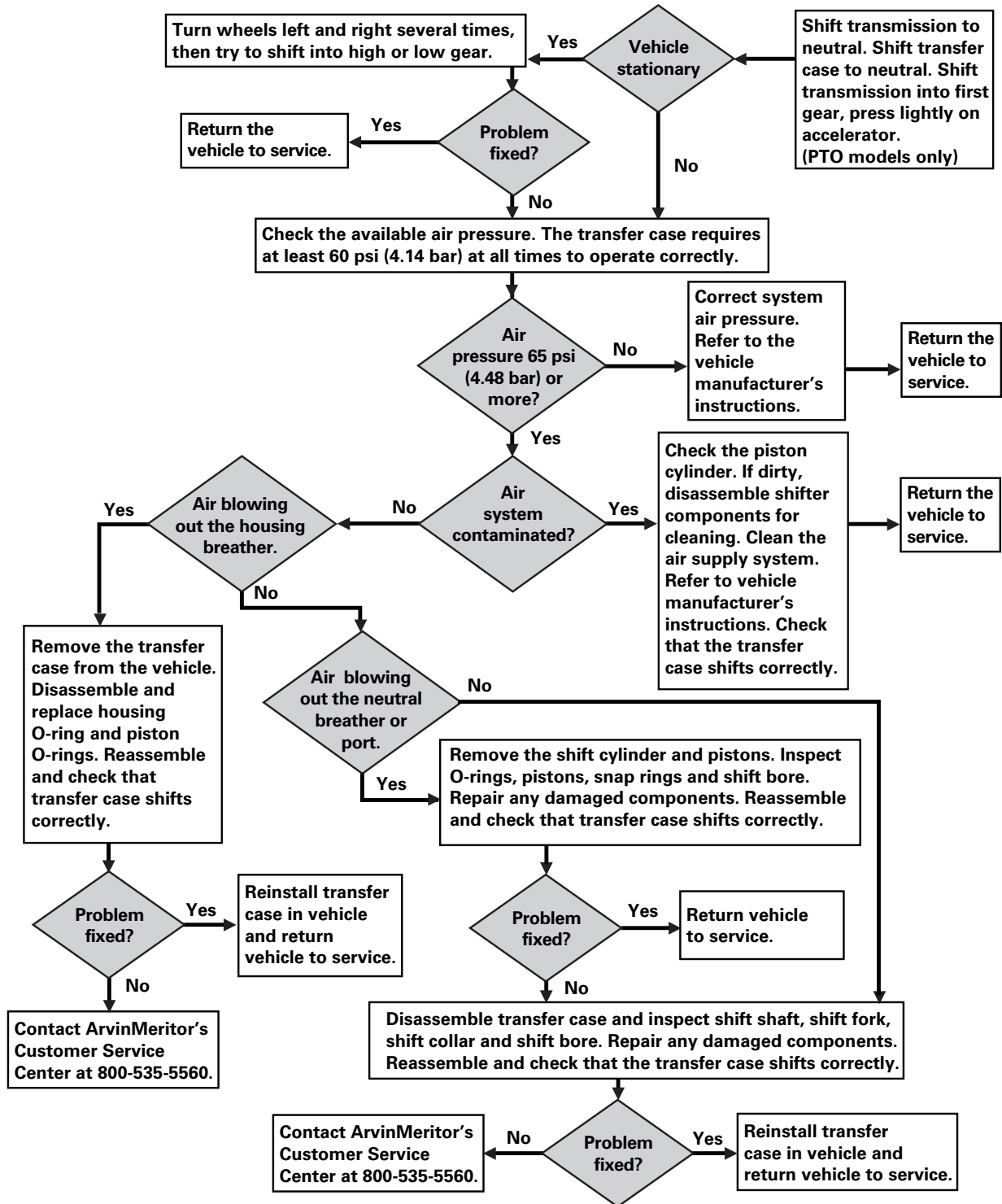

4001530c

Hazard Alert Messages

Read and observe all Warning and Caution hazard alert messages in this publication. They provide information that can help prevent serious personal injury, damage to components, or both.

WARNING

To prevent serious eye injury, always wear safe eye protection when you perform vehicle maintenance or service.

How to Obtain Additional Lubrication and Maintenance Information

For complete lubrication information for Meritor's transfer cases, refer to Maintenance Manual 1, Preventive Maintenance and Lubrication. To obtain a copy of this publication or access it on ArvinMeritor's website, refer to the Service Notes page on the inside front cover of this manual.

Lubricant Temperatures

Meritor MTC-4208, MTC-4209 and MTC-4210 Series Transfer Cases

CAUTION

Meritor MTC-4208, MTC-4209 and MTC-4210 Series transfer cases may operate with an oil temperature above 300° F (148° C). However, if the oil temperature reaches 350° F (177° C), stop the vehicle immediately. Check for the cause of overheating to prevent damage to components.

Meritor MTC-4208, MTC-4209 and MTC-4210 Series transfer cases may operate with an oil temperature above 300° F (148° C). However, if the oil temperature reaches 350° F (177° C), stop the vehicle immediately and check for the cause of overheating. Oil temperatures at this range should only occur in linehaul or utility applications that operate under high speed for long periods of time.

Do Not Install API GL-5 Oils

CAUTION

Meritor does not approve petroleum-based and multiviscosity oil. Do not install API GL-5 oils, which contain extreme-pressure (EP) additives. These additives can form sludge at normal operating temperatures. Damage to components can result. Use only SAE Grade 50W synthetic oil in the transfer case.

Use only SAE Grade 50W oil, Meritor specification O-81, in the transfer case.

Do not install API GL-5 oils in a transfer case. This specification contains extreme pressure (EP) additives that can form sludge at normal operating temperatures and damage transfer case components.

Petroleum-Base and Multi-Viscosity Oils

Meritor does not approve the use of petroleum-base and multi-viscosity motor oils. Refer to Maintenance Manual 1, Preventive Maintenance and Lubrication; or TP-90114, Transmission Lubricant Specifications, for a list of approved oils.

Meritor does approve the use of synthetic-base oils.

Operating Information

Magnets and Magnetic Drain Plugs

Most Meritor transfer cases are equipped with magnetic drain plugs with a minimum pick-up capacity of 20 ounces (0.57 kg) of low carbon steel. Replace the magnetic drain plug each time you change the oil. Use the correct part. If you use a pipe plug instead of a drain plug, the pipe plug will leak.

You can reuse a drain plug you removed if it has a minimum pick-up capacity of 20 ounces (0.57 kg) of low carbon steel after you clean it.

Breather

CAUTION

Cover the breather when steam cleaning the housing. If the breather is not covered, water can enter the housing and contaminate the oil.

The breather releases pressure that builds up inside the transfer case during vehicle operation. Figure 10.1 and Figure 10.2.

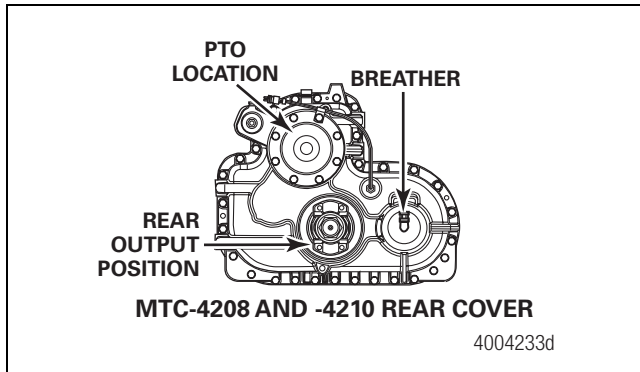

Figure 10.1

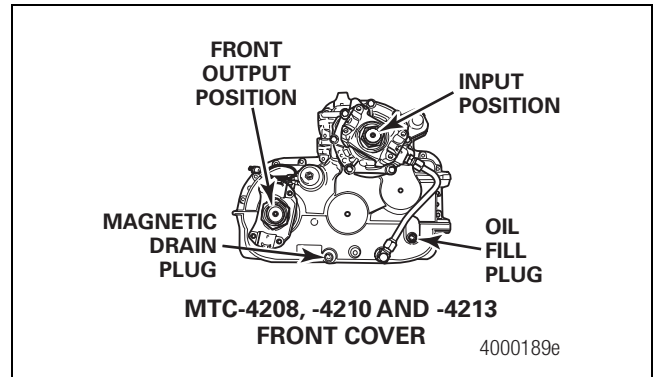

Figure 10.3

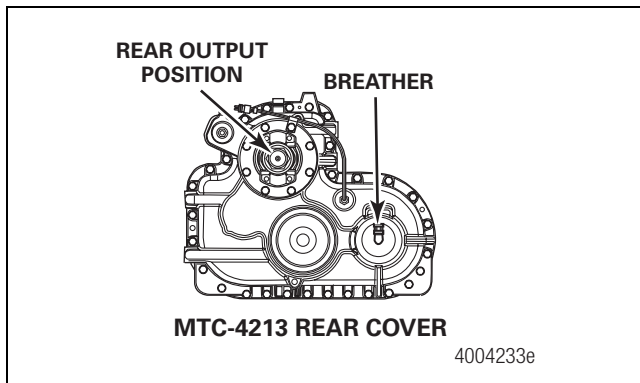

Figure 10.2

Seals

CAUTION

Always use the correct tools and procedures when you replace a seal. A seal that is not correctly installed can leak. Damage to components can result.

Seals keep lubricant in and dirt out of a component. When they are worn or damaged, seals leak and produce low lubricant levels which may damage components.

Always replace unitized seals after yokes have been removed. MLS seals may be reused if they are not damaged or leaking.

Meritor has released the multiple-lip seal (MLS) for use in the INPUT POSITION ONLY on the MTC-4208, -4210 and -4213 transfer cases. The multiple-lip seal is compatible with the current input shaft seal and can be used in service. Refer to Figure 10.3 for the INPUT position and front OUTPUT position. Refer to Figure 10.1 for the MTC-4208 and -4210 rear OUTPUT position. Refer to Figure 10.2 for the MTC-4213 rear OUTPUT position.

CAUTION

Only install the Meritor multi-lip unidirectional seal at the input position from the transmission in an MTC-4208, MTC-4210 or MTC-4213 Series transfer case. If you install the multi-lip seal in either the rear output position or forward output position on these transfer cases, loss of lubricant and damage to components can occur.

The multiple-lip seal must be serviced with the seal and sleeve. The service part number provides both when required. Check your application carefully before installing the multiple-lip seal.

Special Tools and Installation Procedure

Refer to Section 6 in this manual for the correct seal installation procedure. To obtain these sleeves, seals and drivers, call ArvinMeritor's Commercial Vehicle Aftermarket at 888-725-9355.

Check and Adjust the Oil Level



⚠ CAUTION

Only use new lubricant when you change or adjust the oil in the transfer case. Do not reuse lubricant, which can contain metallic particles and other contaminants. Damage to components can result.

Meritor does not approve petroleum-based and multiviscosity oil. Do not install API GL-5 oils, which contain extreme-pressure (EP) additives. These additives can form sludge at normal operating temperatures. Damage to components can result. Use only SAE Grade 50W synthetic oil in the transfer case.

Do not operate the transfer case if the oil level is below the bottom of the fill hole, which may be an indication that the transfer case is leaking. Damage to components can result. If the transfer case is leaking, repair the leak. Adjust the oil level before returning the transfer case to service.

When servicing the transfer case, add the specified lubricant until the oil level is even with the fill hole. Do not overfill the transfer case, which can cause the transfer case to overheat. Damage to components can result.

1. Park the vehicle on a level surface.
2. Clean the area around the fill plug. Remove the fill plug from the transfer case. Figure 10.4. The oil level must be even with the bottom of the fill plug hole.
 - **If oil flows from the hole when you loosen the plug:** The oil level is high. Drain the oil to the bottom of the fill hole.
 - **If the oil level is below the bottom of fill/level plug hole:** Add SAE Grade 50W full-synthetic oil (Meritor specification O-81) into the transfer case until oil is even with the bottom of the fill hole.
3. Install and tighten the fill plug to 35-50 lb-ft (47-68 N•m). 
4. Test drive the vehicle for at least one mile (1.6 km). Allow the oil to settle for five minutes and recheck the fluid level. Top off the oil level by adding oil to the fill opening. Reinstall and tighten the fill plug to 35-50 lb-ft (47-68 N•m). 

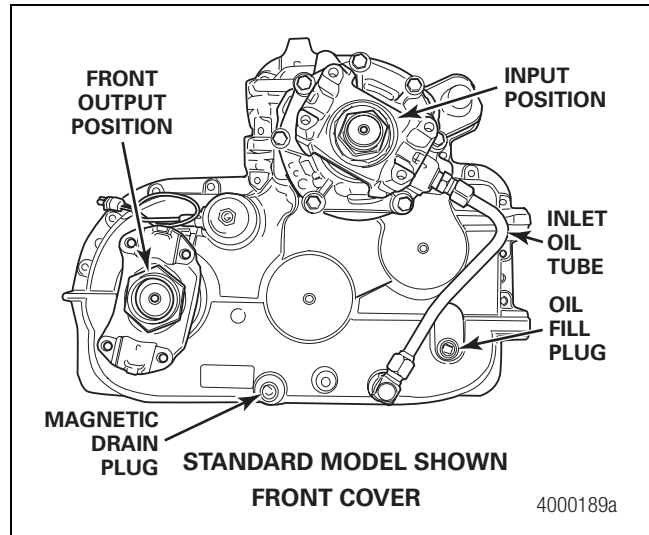





Figure 10.4

Drain and Replace the Oil

1. Park the vehicle on a level surface. Place a large container under the transfer case.
2. Remove the magnetic drain plug from the bottom of the transfer case. Drain and discard the oil correctly. Clean the plug. Figure 10.4.
3. Install and tighten the drain plug to 35-50 lb-ft (47-69 N•m). Clean the area around the fill plug. Remove the fill plug from the transfer case. 
4. Add SAE Grade 50W full-synthetic oil (Meritor specification O-81) into the transfer case until the oil level is even with the bottom of the fill plug hole. Install and tighten the fill plug to 35-50 lb-ft (47-68 N•m). 
5. Test drive the vehicle for at least one mile (1.6 km). Allow the oil to settle for five minutes and recheck the fluid level. Top off the oil level by adding oil to the fill opening. Reinstall and tighten the fill plug to 35-50 lb-ft (47-68 N•m). 

Inspection

Meritor MTC-4208, -4210 and -4213 Transfer Case Inspection

Visually inspect the Meritor MTC-4208, -4210 and -4213 transfer cases daily for any leaks. The oil level should be inspected every 1,000 miles (1069 km), 100 hours or every month, whichever comes first. In addition, the transfer case should be inspected for leaks and the correct oil level before and after extended time high speed road trips. Areas to inspect are:

- Cooler lines and fittings
- Seals
- Breather
- Fill and drain plugs
- Pump inlet tube and fittings
- Gaskets and shims
- During the inspection visually check to ensure the transfer case oil level is to the bottom of the oil fill hole.

Operation	Frequency
Inspect for oil leaks	Daily
Check oil level	1,000 miles (1609 km), 100 hours or every month, whichever occurs first
Check oil level	Before and after extended time high speed road trips
Initial oil change	2,500 miles (4000 km) or 125 hours, whichever occurs first
Synthetic oil change	Every 25,000 miles (40 000 km), 1,250 hours or every 12 months, whichever occurs first

Table F: Transfer Case Oil Specifications

Oil Description ^{1, 2}	Meritor Specification	A.P.I. Specification	Military Specification	SAE Grade	Outside Temperature
Full Synthetic Oil ³	0-81	—	—	50W	Above -40° F (-40° C)
A.P.I. GL-5 (Axle Lube) ⁴			DO NOT USE IN TRANSFER CASES		

¹ Do not mix or switch oil types. Use the same oil that initially filled the transfer case.

² Do not use multi-viscosity oils.

³ Meritor-approved full synthetic oil for Meritor manual transmissions is also approved for Meritor transfer cases. Refer to publication TP-90114, Transmission Lubricant Specifications, for a list of approved distributors.

⁴ Do not use multi-viscosity (i.e., 80/90W) GL-5 Gear Oil, axle lube.

10 Lubrication and Maintenance

Table G: Transfer Case Oil Capacities

Transfer Case Model	Oil Capacity	
	Pints ^{1,2}	Liters ^{1,2}
MTC-4213	9.0	4.26
MTC-4210	9.0	4.26
MTC-4208	9.0	4.26

¹ Due to the varied transfer case configurations, these fill quantities are for reference only. The fill procedure for all transfer cases is in this section.

² Oil cooler equipped vehicles will use additional oil to compensate for the cooler and cooler lines.

Table H: Dry Weight

Unit	Weight lbs (kg)
Base Model	670 (304)
PTO	65 (29.5)

Table I: Transfer Case Model

Transfer Case Model	Seal Position	Seal Service Part Number	Previous Seal Part Number	Seal Driver	Sleeve Driver
MTC-4208, -4210 and -4213	Input Shaft	A1-1205X2728	R945007	2728T1	2728T2
MTC-4208 and -4210	Forward and Rear Output	R945007	A 1205R2592	KIT 4454	NA
MTC-4213	Forward Output	R945007	A 1205R2592	KIT 4454	NA
MTC-4213	Rear Output	R945010	A 1205Q2591	KIT 4454	NA
MTC-4208 and -4210	PTO Seal	R945008	A 1205P2590	KIT 4454	NA

Torque Specifications

OIL COOLER READY MODEL

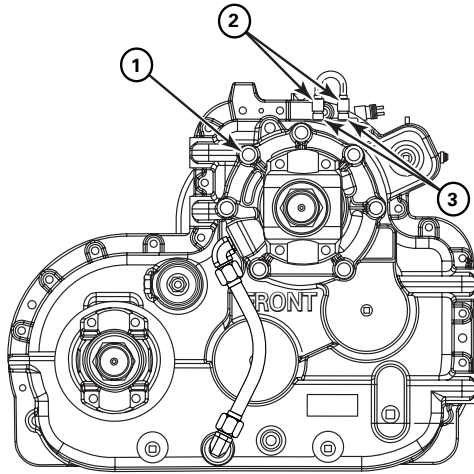

STANDARD MODEL

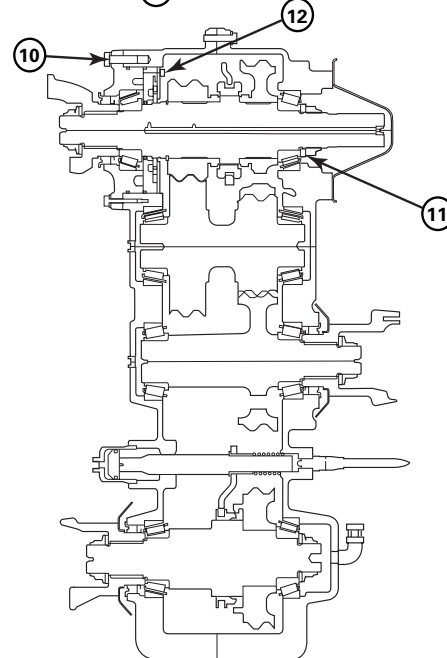
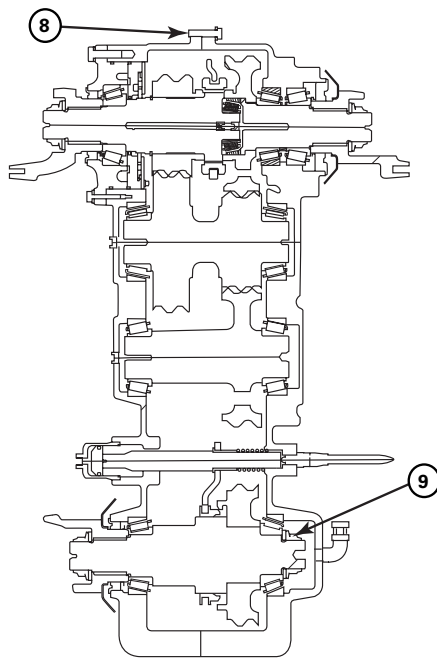
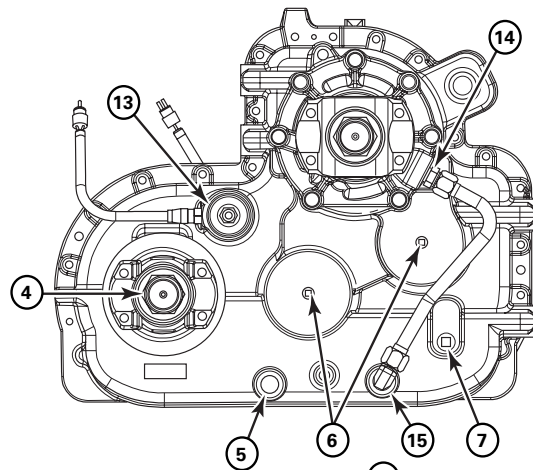

4000229c

Item	Description	Torque lb-ft (N•m)
1	Bearing Cage Cover Capscrews	85-115 (115-156)
2	Loop Tube Fittings	20 (27)
3	Oil Cooler Male Connectors*	25 (34)
4	Yoke Locknuts	700-900 (949-1220)
5	Magnetic Drain Plug	35-50 (48-68)
6	3/8-Inch (9.5 mm) Plug	20-25 (27-34)
7	Fill Plug	35-50 (48-68)
8	Cover-to-Case Capscrews	60-75 (81-102)

Item	Description	Torque lb-ft (N•m)
9	Shaft Locknut	700-900 (949-1220)
10	Bearing Cage Capscrews	85-115 (115-156)
11	Shaft Locknut	700-900 (949-1220)
12	Oil Pump Capscrews	22-29 (29-39)
13	Shift Cylinders	85-95 (115-129)
14	Male Connector	35-50 (48-68)
15	Fitting — Screen	35-50 (48-68)

* Apply Loctite® 582 threadlocker to pipe threads

12 Vehicle Towing Instructions

Guidelines

CAUTION

Follow towing procedures recommended by Meritor to prevent internal damage to the transfer case.

Meritor recommends that you use one of the two methods below when towing a vehicle equipped with an MTC-4208, -4210 or -4213 transfer case to prevent damage to the transfer case.

NOTE: For complete towing information and instructions on axle shaft removal, refer to Technical Bulletin TP-9579, Driver Instruction Kit.

Method 1

Remove both axle shafts from the axles that will remain on the road when the vehicle is transported.

Method 2

Remove the drive shafts from axles that contact the ground.

Tool Drawing

OPTIONAL FABRICATION METHOD:
 Use standard 1" square drive 3" hex socket, splice drive section apart from hex section, weld a tubular section (3.00 ID x 4.75 OD x 2.50 length) between hex and drive sections.

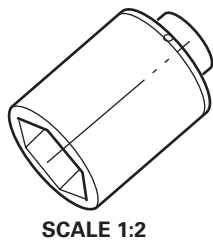
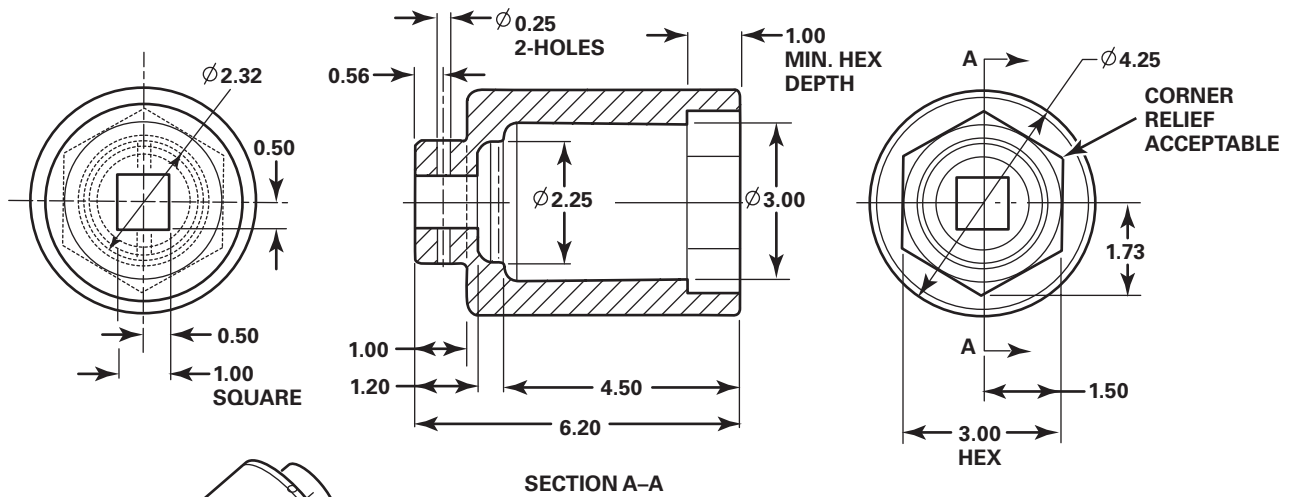
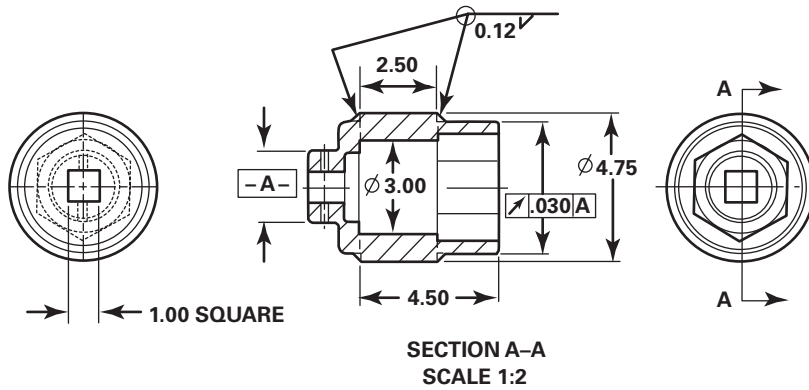

4004222a

Meritor Heavy Vehicle Systems, LLC

2135 West Maple Road
Troy, MI 48084 USA
800-535-5560
arvinmeritor.com

Copyright 2008
ArvinMeritor, Inc.

Printed in USA

Revised 12-08
Maintenance Manual MM-0146 (16579/22882)

ArvinMeritor™